

① ELEVATION VIEW

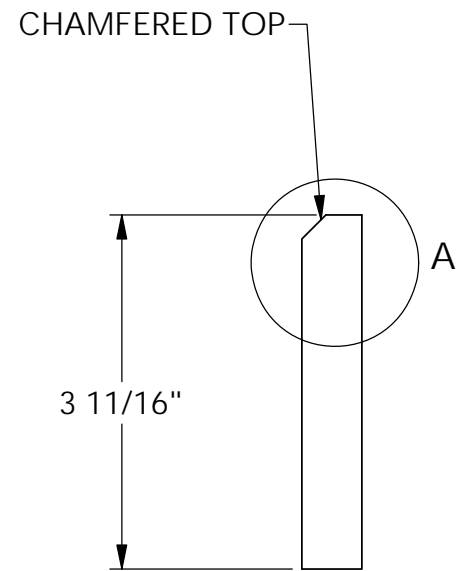

② SECTION

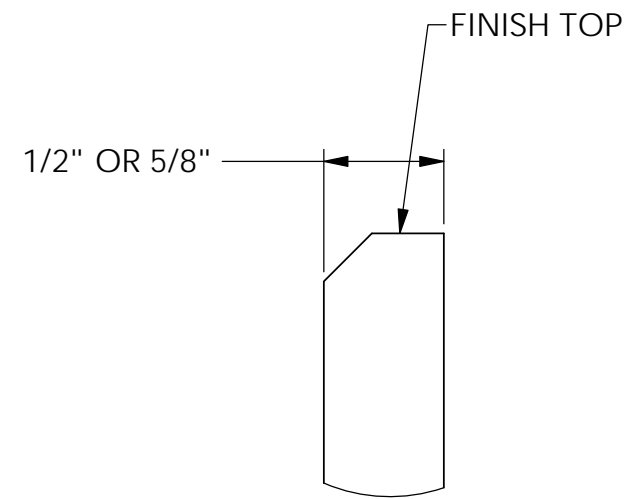

DETAIL A  
SCALE 1 : 1

QUANTITY NEEDED: \_\_\_\_\_ PIECES

COLOR NEEDED: \_\_\_\_\_

LEFT OUTCORNER: \_\_\_\_\_

RIGHT OUTCORNER: \_\_\_\_\_



**WAUSAU TILE**

P.O. BOX 1520, WAUSAU, WI 54402-1520  
800-388-8728  
EMAIL: WTILE@WAUSAUTILE.COM  
WEBSITE: WWW.WAUSAUTILE.COM

REVISIONS

	BY	DATE	NOTE
1	-		-
2	-		-
3	-		-
4	-		-
5			

**CONFIDENTIAL INFORMATION**

THESE DRAWINGS, SPECIFICATIONS AND OTHER INFORMATION AND DOCUMENTS ACCOMPANYING THEM ARE THE CONFIDENTIAL AND PROPRIETARY PROPERTY OF WAUSAU TILE, INC. THE DRAWINGS THEMSELVES SHALL BELONG TO THE OWNER FOR USE ONLY ON THE PROJECT. ANY ADDITIONAL USE SHALL REQUIRE THE PRIOR WRITTEN APPROVAL OF WAUSAU TILE, INC. THE PROPRIETARY INFORMATION CONTAINED WITHIN THE DRAWINGS AND THE DOCUMENTS IS AND SHALL REMAIN THE SOLE PROPERTY OF WAUSAU TILE, INC.

UNLESS OTHERWISE SPECIFIED DIMENSIONS SHOWN ARE ROUNDED TO THE CLOSEST FRACTION ± 1/16"

DRAWING SCALE: NOT TO SCALE

FABRICATION TOLERANCE: ± 1/8"

**TYPE "D"  
CHAMFERED TOP  
4" X 16" NOMINAL**

CUSTOMER SIGNATURE REQUIRED

APPROVED: \_\_\_\_\_

DATE: \_\_\_\_\_

(SIGNATURE ABOVE ILLUSTRATES YOU HAVE REVIEWED ALL ASPECTS OF THE DESIGN FOR ACCURACY AND COMPLIANCE WITH YOUR JOB REQUIREMENTS AND APPROVE FABRICATION AS REPRESENTED WITHIN THESE DRAWINGS)

DRAWN BY: MCR DATE: 04/30/2020

CO NUMBER: -

WEIGHT: #

PRODUCT NUMBER:

**4" X 16" CHAMFERED**