



WAUSAU TILE

P.O. BOX 1520, WAUSAU, WI 54402-1520
800-388-8728
EMAIL: WTILE@WAUSAUTILE.COM
WEBSITE: WWW.WAUSAUTILE.COM

REVISIONS

	BY	DATE	NOTE
1	-		-
2	-		-
3	-		-
4	-		-
5			

CONFIDENTIAL INFORMATION
THESE DRAWINGS, SPECIFICATIONS AND OTHER INFORMATION AND DOCUMENTS ACCOMPANYING THEM ARE THE CONFIDENTIAL AND PROPRIETARY PROPERTY OF WAUSAU TILE, INC. THE DRAWINGS THEMSELVES SHALL BELONG TO THE OWNER FOR USE ONLY ON THE PROJECT. ANY ADDITIONAL USE SHALL REQUIRE THE PRIOR WRITTEN APPROVAL OF WAUSAU TILE, INC. THE PROPRIETARY INFORMATION CONTAINED WITHIN THE DRAWINGS AND THE DOCUMENTS IS AND SHALL REMAIN THE SOLE PROPERTY OF WAUSAU TILE, INC.

UNLESS OTHERWISE SPECIFIED DIMENSIONS SHOWN ARE ROUNDED TO THE CLOSEST FRACTION ± 1/16"

DRAWING SCALE: NOT TO SCALE

FABRICATION TOLERANCE: ± 1/8"

ZB.TO.03

CUSTOMER SIGNATURE REQUIRED

APPROVED: _____

DATE: _____

(SIGNATURE ABOVE ILLUSTRATES YOU HAVE REVIEWED ALL ASPECTS OF THE DESIGN FOR ACCURACY AND COMPLIANCE WITH YOUR JOB REQUIREMENTS WITH YOUR JOB REQUIREMENTS AS REPRESENTED WITHIN THESE DRAWINGS.)
DRAWN BY: APPROVED BY: FABRICATION AS REPRESENTED WITHIN THESE MDW DRAWINGS 2/4/2020

CO NUMBER: -

WEIGHT: # 1274

PRODUCT NUMBER: ZB.TO.03.WITH.SEATS

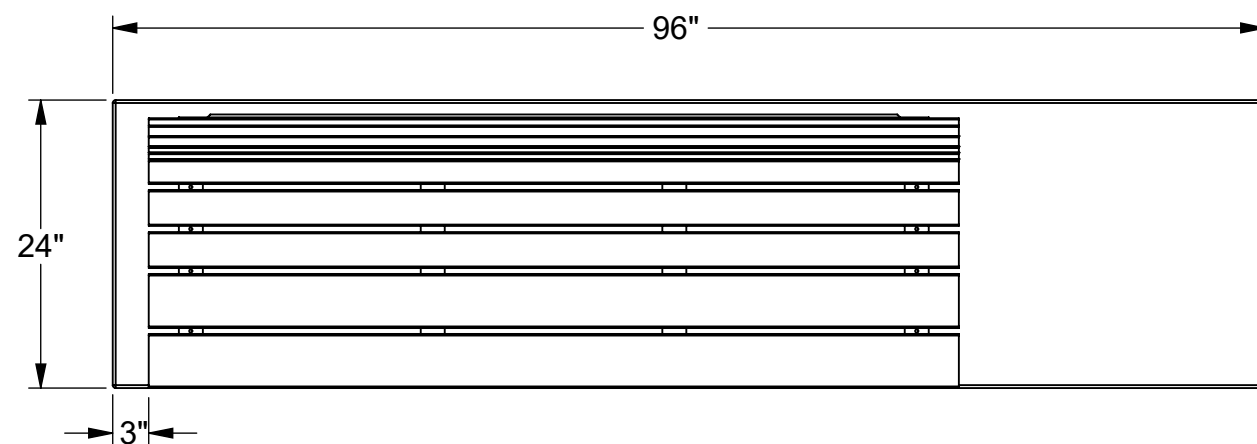

① TOP VIEW

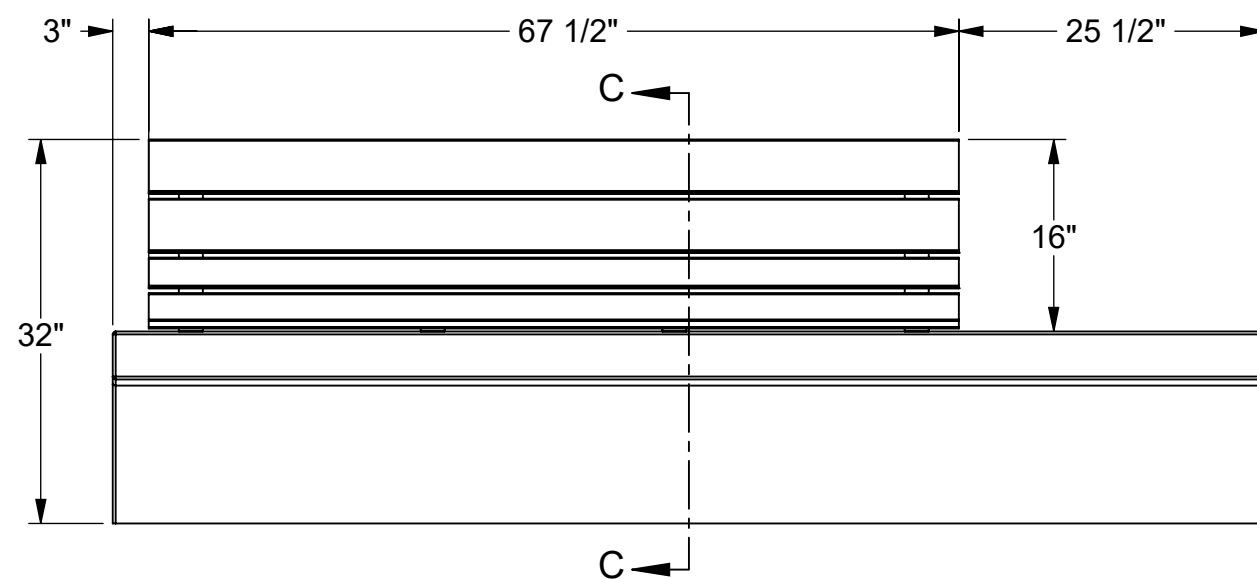

② FRONT VIEW

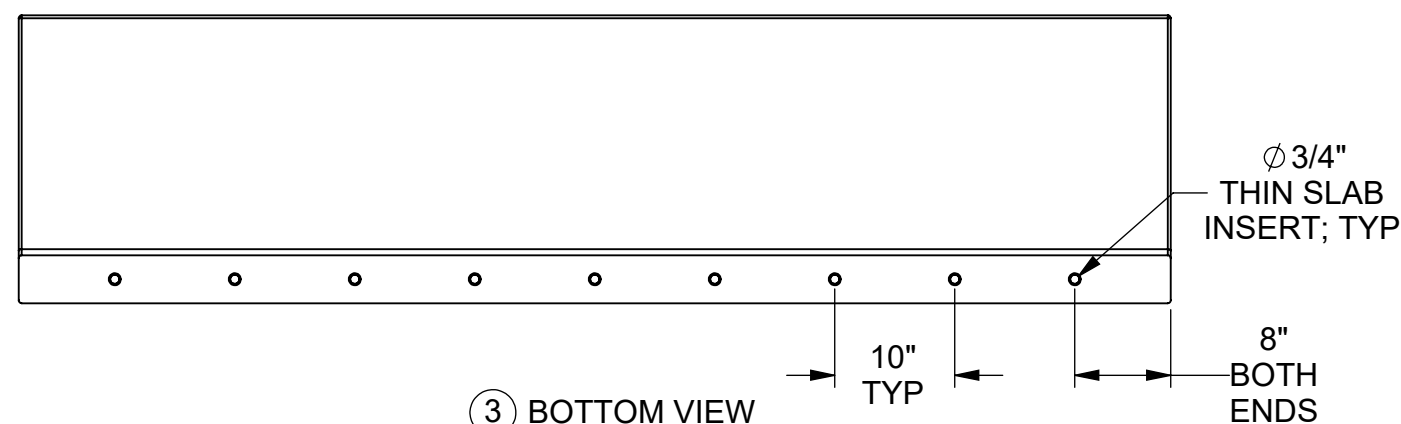

③ BOTTOM VIEW

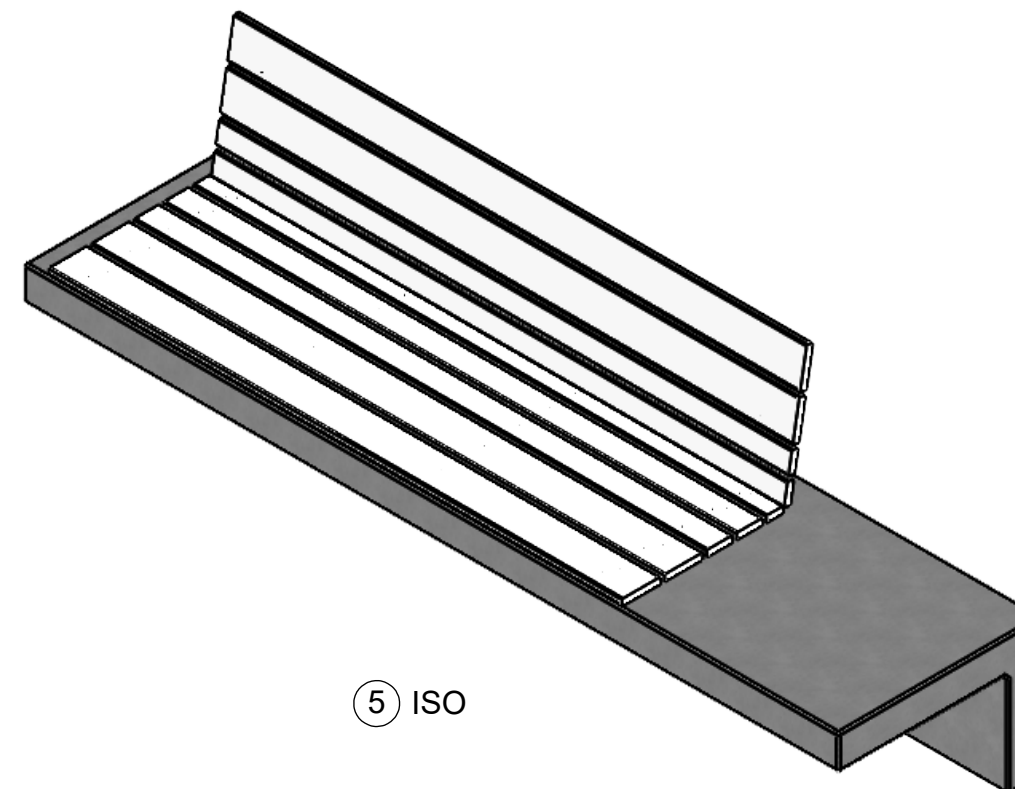

⑤ ISO

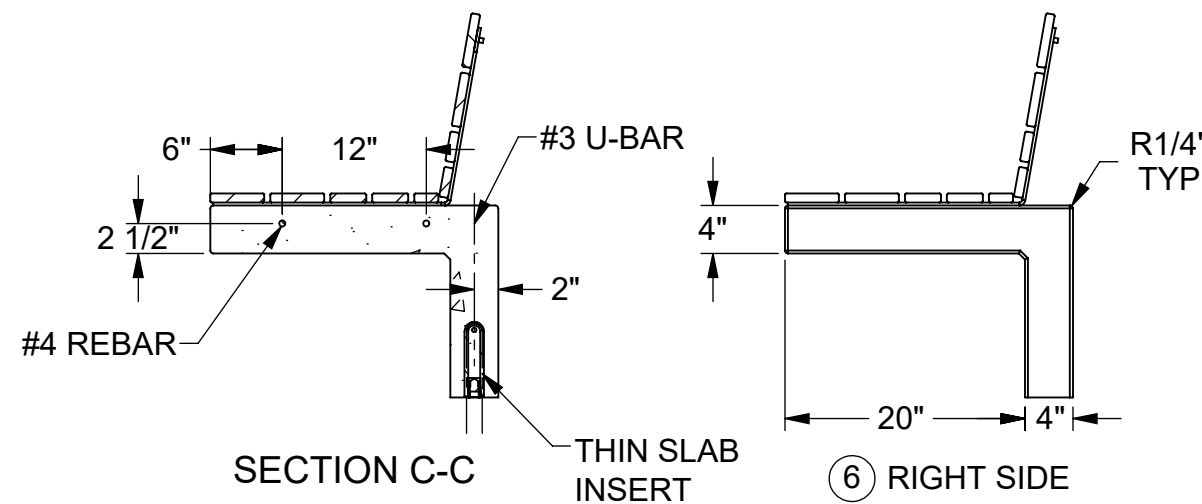

SECTION C-C

④ SECTION

⑥ RIGHT SIDE