



**WAUSAU TILE**  
 P. O. BOX 1520 WAUSAU, WI 54402-1520  
 800-388-8728  
 E-MAIL: [WTL@WAUSAUTILE.COM](mailto:WTL@WAUSAUTILE.COM)  
 WEBSITE: [WWW.WAUSAUTILE.COM](http://WWW.WAUSAUTILE.COM)

REVISIONS

BY	DATE	NOTES
1		
2		
3		
4		
5		
6		

CONFIDENTIAL INFORMATION  
 THESE DRAWING, SPECIFICATIONS AND OTHER INFORMATION AND DOCUMENTS ACCOMPANYING THEM ARE THE CONFIDENTIAL AND PROPRIETARY PROPERTY OF WAUSAU TILE, INC. THE DRAWINGS THEMSELVES SHALL BELONG TO THE OWNER FOR USE ONLY ON THE PROJECT. ANY ADDITIONAL USE SHALL REQUIRE THE PRIOR WRITTEN APPROVAL OF WAUSAU TILE, INC. THE PROPRIETARY INFORMATION CONTAINED WITHIN THE DRAWINGS AND THE DOCUMENTS IS AND SHALL REMAIN THE SOLE PROPERTY OF WAUSAU TILE, INC.

UNLESS OTHERWISE SPECIFIED DIMENSIONS SHOWN ARE ROUNDED TO THE CLOSEST FRACTION + 1/16"

DRAWING SCALE: NOT TO SCALE

FABRICATION TOLERANCE: ± 1/8"

**JOB NAME**

CUSTOMER SIGNATURE REQUIRED

APPROVED: \_\_\_\_\_

DATE: \_\_\_\_\_

(SIGNATURE ABOVE ILLUSTRATES YOU HAVE REVIEWED ALL ASPECTS OF THE DESIGN AND APPROVE FABRICATION AS REPRESENTED WITHIN THESE DRAWINGS)

DRAWN BY: **PW** PROJ MNGR: \_\_\_\_\_

DATE: **04/04/24**

FINISH/COLOR: \_\_\_\_\_

SEALER: \_\_\_\_\_

WEIGHT (LBS): **1450**

CO NUMBER: **CO** \_\_\_\_\_

REFERENCE: **ZB.PB.01**

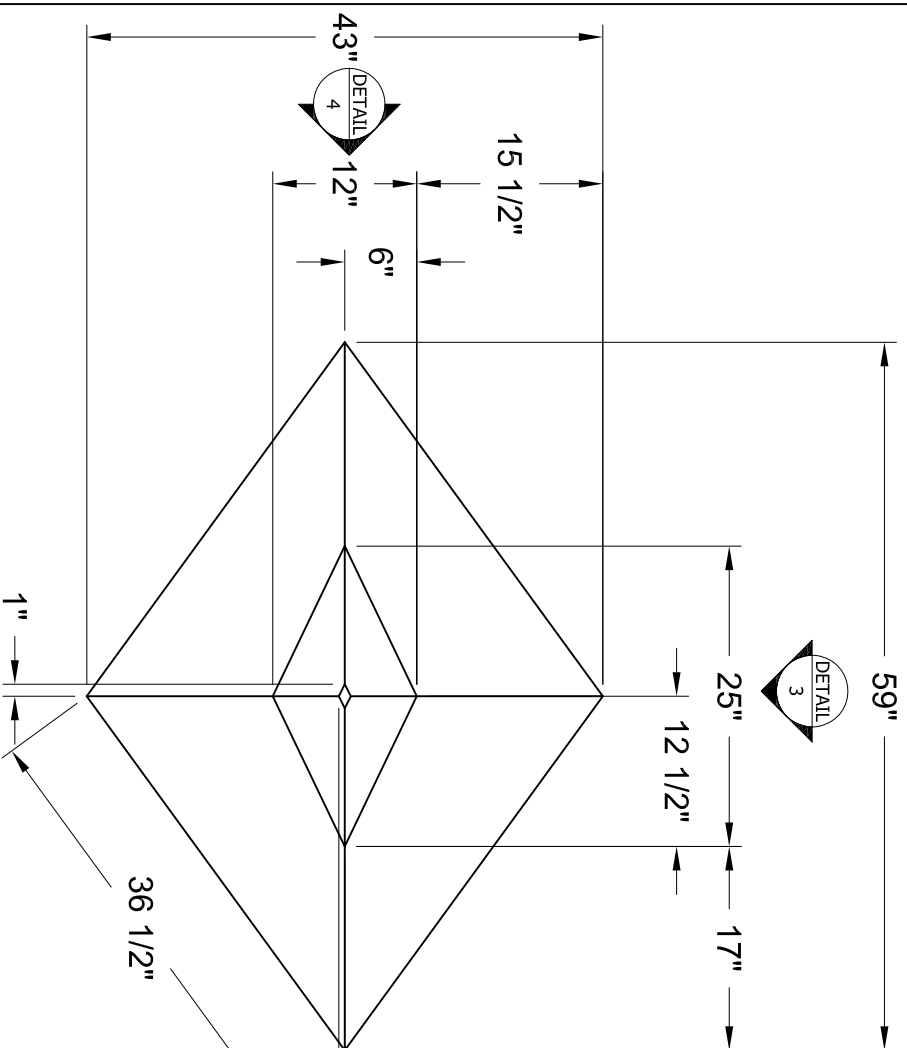

**1** TOP VIEW  
 SCALE: 3/4" = 1'

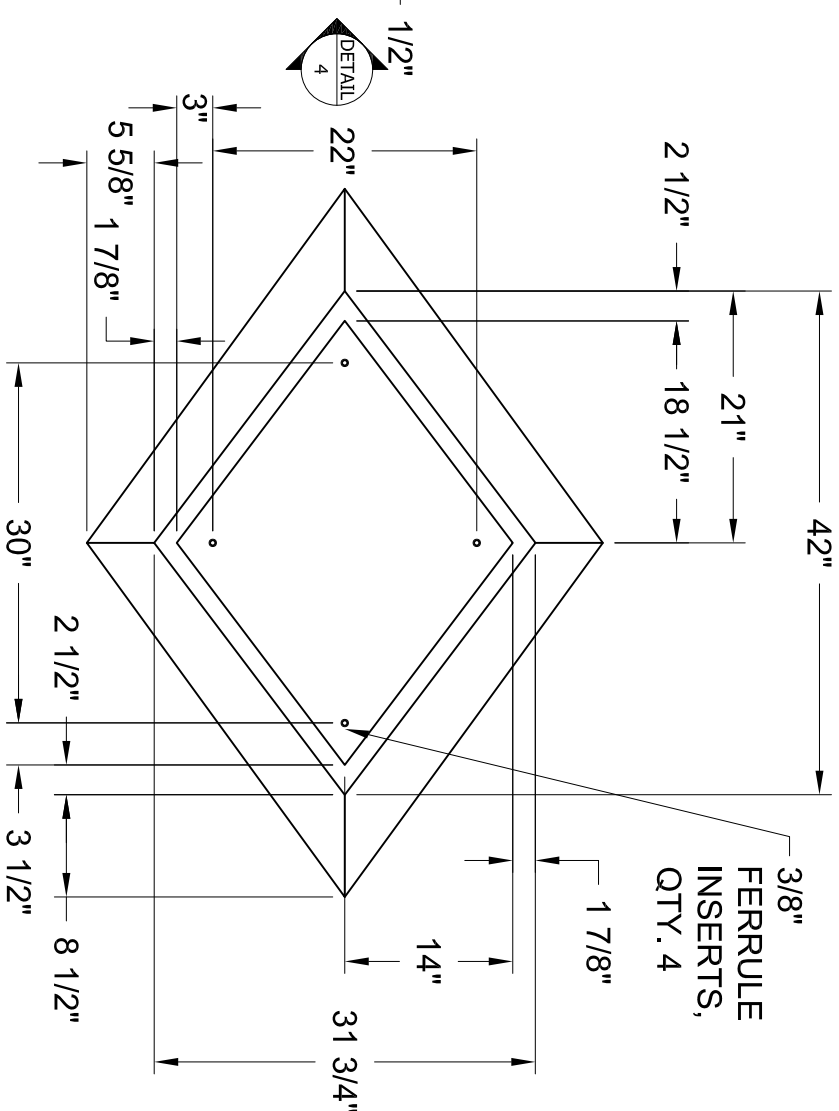

**2** BOTTOM VIEW  
 SCALE: 3/4" = 1'

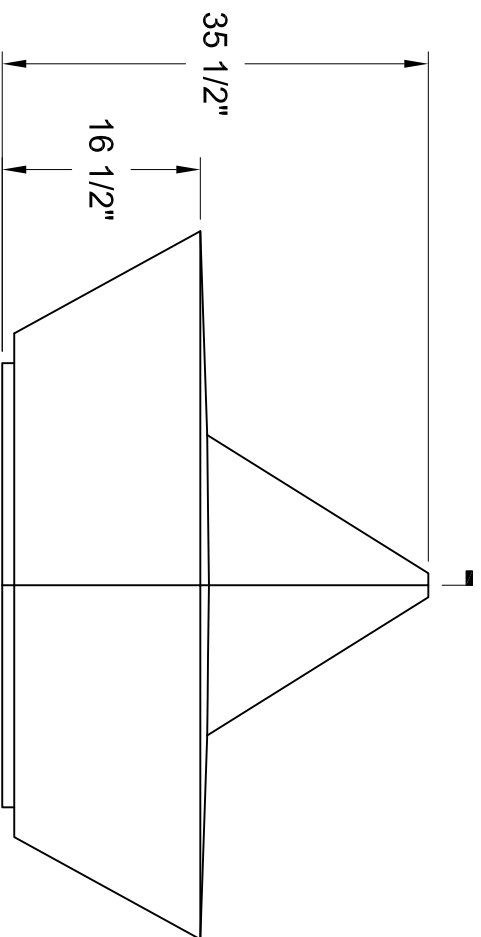

**3** ELEVATION VIEW  
 SCALE: 3/4" = 1'

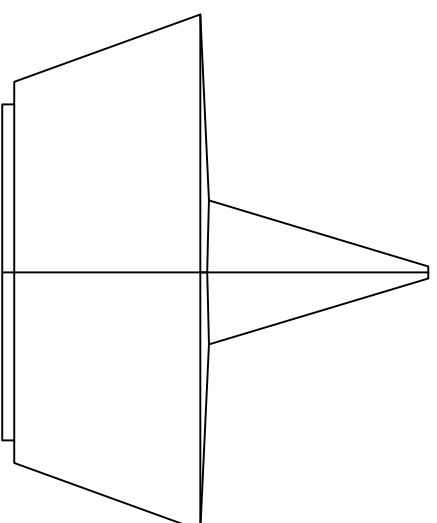

**4** ELEVATION VIEW  
 SCALE: 3/4" = 1'

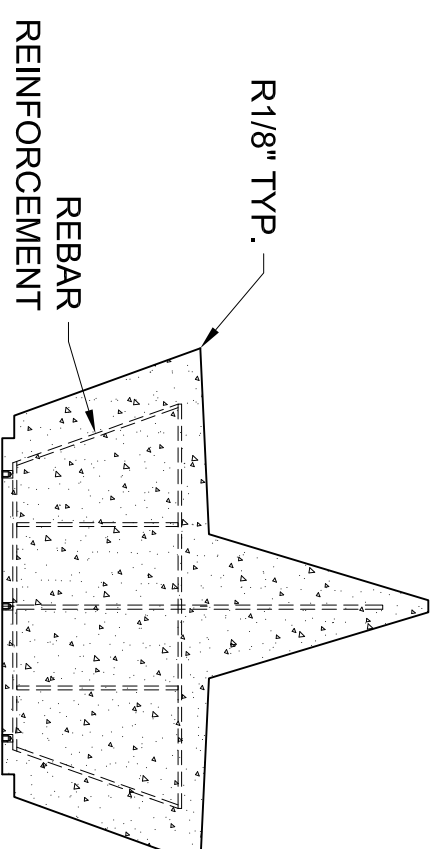

**5** SECTION VIEW  
 SCALE: 3/4" = 1'