

REVISIONS

NAME	DATE	NOTES
1	---	---
2	---	---
3	---	---
4	---	---
5	---	---
6	---	---
7	---	---
8	---	---

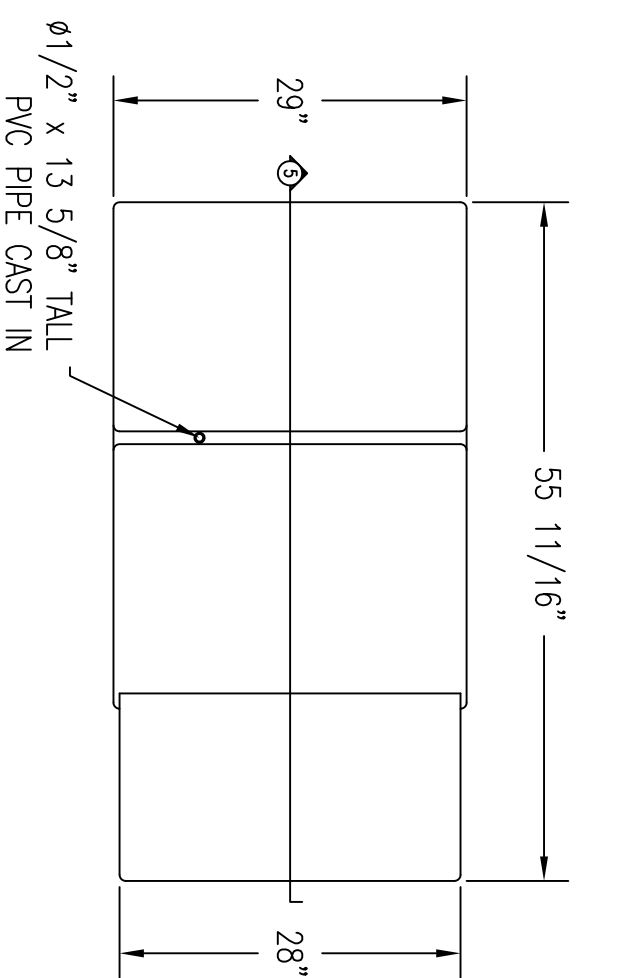

1 TOP VIEW
 Scale: 1/16" = 1"

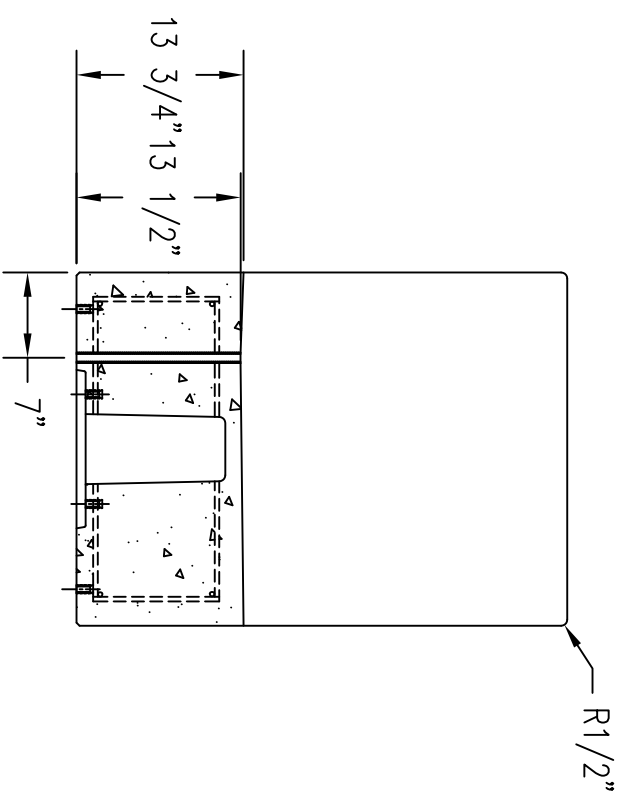

3 FRONT VIEW
 Scale: 1/16" = 1"

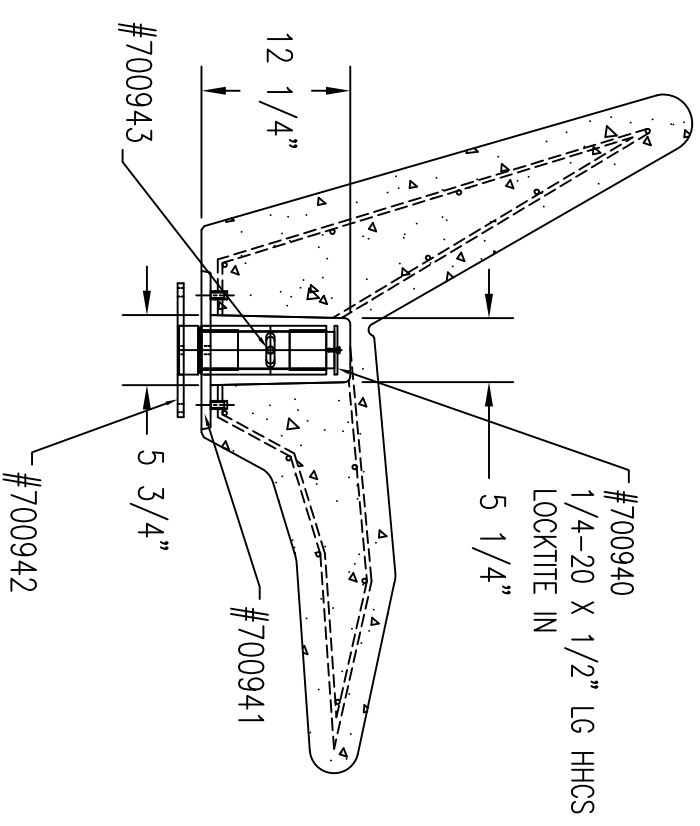

5 SECTION VIEW
 Scale: 1/16" = 1"

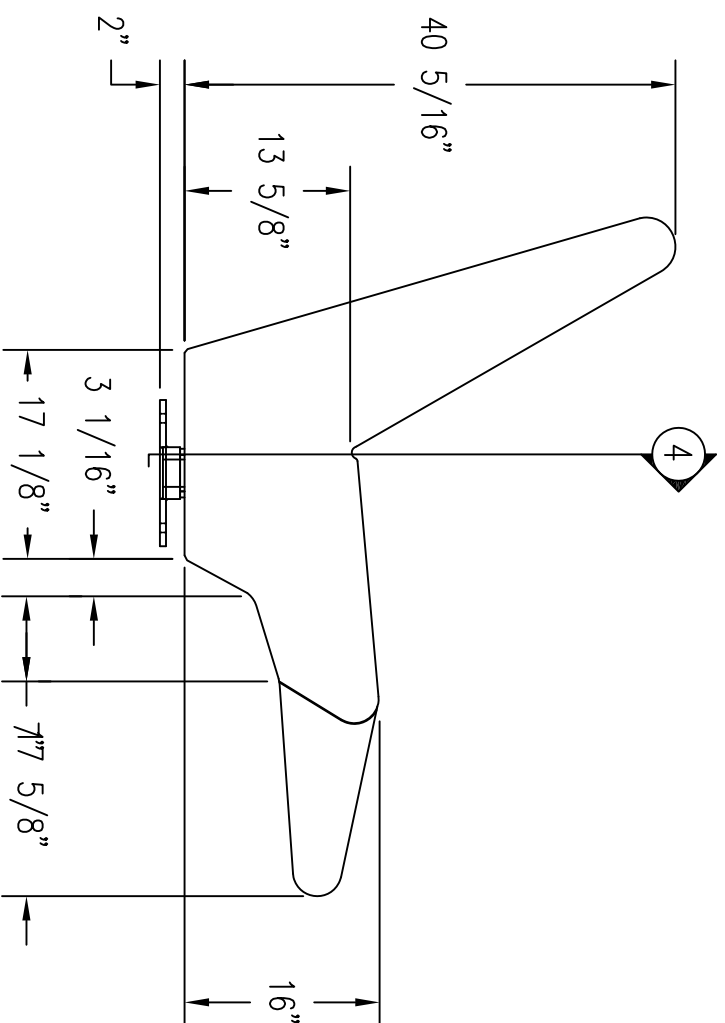

2 SIDE VIEW
 Scale: 1/16" = 1"

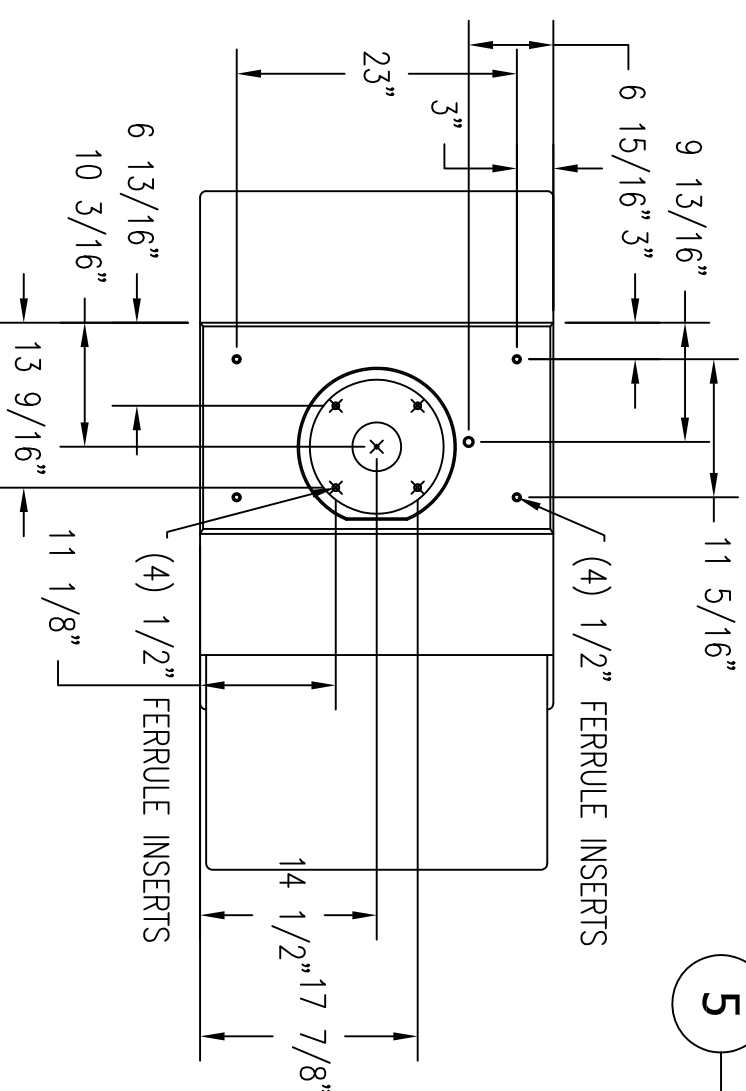

4 BOTTOM VIEW
 Scale: 1/16" = 1"

CONFIDENTIAL INFORMATION
 THESE DRAWING, SPECIFICATIONS AND OTHER INFORMATION AND DOCUMENTS ACCOMPANYING THEM ARE THE CONFIDENTIAL AND PROPRIETARY PROPERTY OF WAUSAU TILE, INC. THE DRAWINGS THEMSELVES SHALL BELONG TO THE OWNER FOR USE ONLY ON THE PROJECT. ANY ADDITIONAL USE SHALL REQUIRE THE PRIOR WRITTEN APPROVAL OF WAUSAU TILE, INC. THE PROPRIETARY INFORMATION CONTAINED WITHIN THE DRAWINGS AND THE DOCUMENTS IS AND SHALL REMAIN THE SOLE PROPERTY OF WAUSAU TILE, INC

JOB NAME

WAUSAU, WI

UNLESS OTHERWISE SPECIFIED DIMENSIONS ARE IN INCHES FRACTIONS ± 1/8"

DRAWN BY: TAS

DATE: 6/30/17

CO NUMBER: ?

WEIGHT: 1700 LBS

SHEET NO.

WS5061