

3/4" ϕ DRAIN HOLE

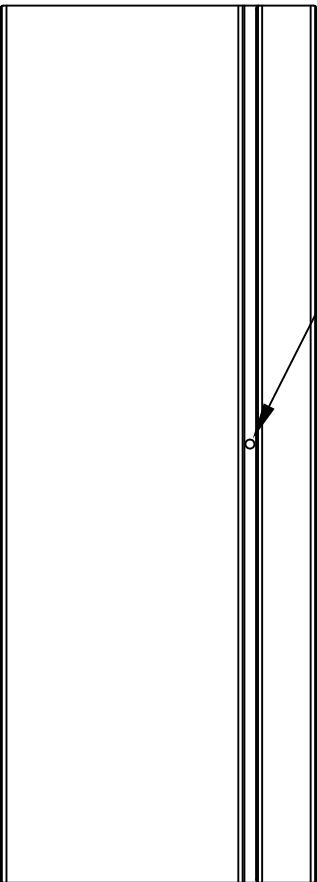

1 TOP VIEW
Scale: 1/16" = 1"

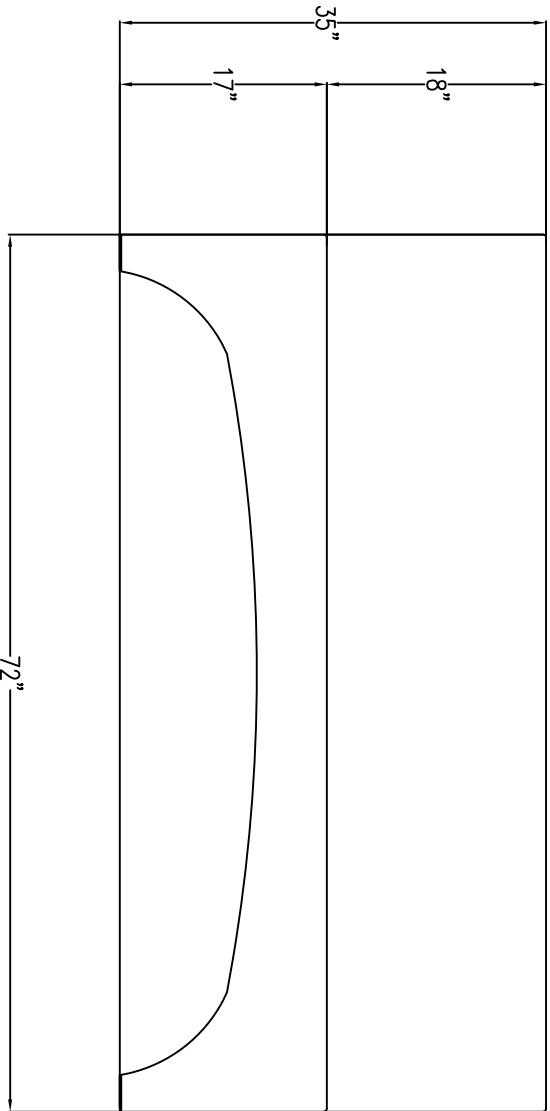

2 FRONT VIEW
Scale: 1/16" = 1"

DRAIN CHANNEL
1/2" SLOPE TO DRAIN

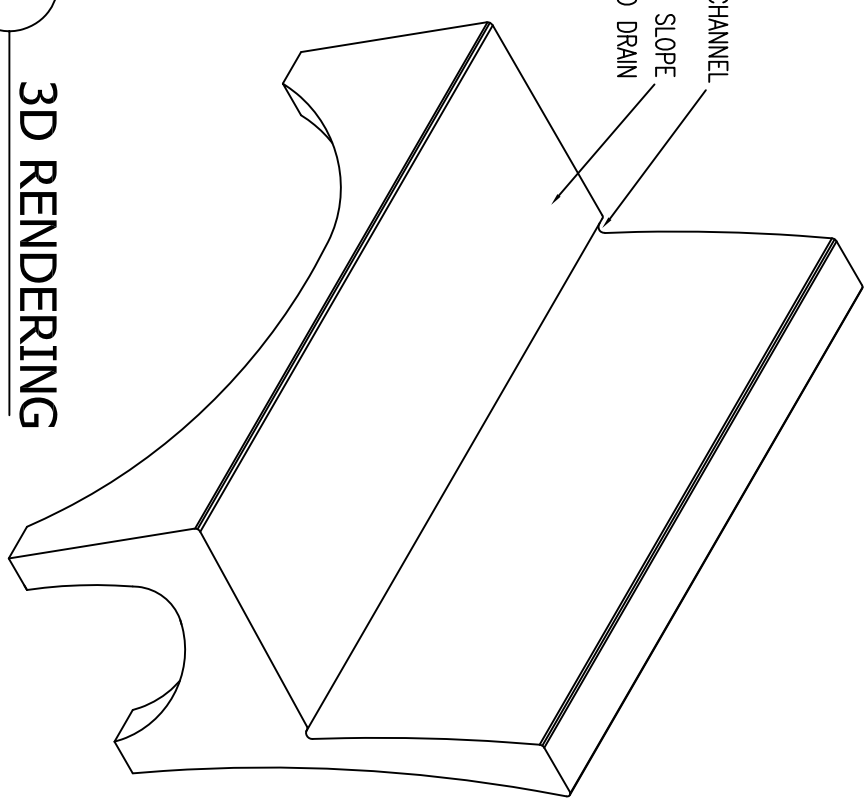

4 3D RENDERING
Scale: 1/16" = 1"

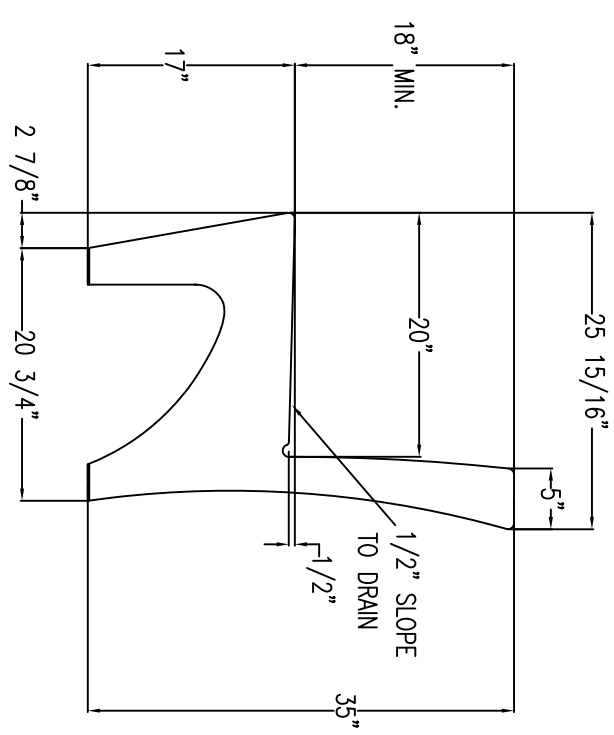

3 SIDE ELEVATION
Scale: 1/16" = 1"



P.O. BOX 1520 WAUSAU, WI 54402-1520
800-388-8728
E-MAIL: WTILE@WAUSAUTILE.COM
WEB SITE: WWW.WAUSAUTILE.COM

REVISIONS		
NAME	DATE	NOTES
1	---	---
2	---	---
3	---	---
4	---	---
5	---	---
6	---	---
7	---	---
8	---	---

CONFIDENTIAL INFORMATION
THESE DRAWING, SPECIFICATIONS AND OTHER INFORMATION AND DOCUMENTS ACCOMPANYING THEM ARE THE CONFIDENTIAL AND PROPRIETARY PROPERTY OF WAUSAU TILE, INC. THE DRAWINGS THEMSELVES SHALL BELONG TO THE OWNER FOR USE ONLY ON THE PROJECT. ANY ADDITIONAL USE SHALL REQUIRE THE PRIOR WRITTEN APPROVAL OF WAUSAU TILE, INC. THE PROPRIETARY INFORMATION CONTAINED WITHIN THE DRAWINGS AND THE DOCUMENTS IS AND SHALL REMAIN THE SOLE PROPERTY OF WAUSAU TILE, INC

WAUSAU TILE INC.

WAUSAU, WI

UNLESS OTHERWISE SPECIFIED DIMENSIONS ARE IN INCHES FRACTIONS $\pm 1/8"$

DRAWN BY: TAS
DATE: 6/29/17
CO NUMBER: ?
WEIGHT: 1250 LBS
SHEET NO. WS5044