

REVISIONS

NAME	DATE	NOTES
1	---	---
2	---	---
3	---	---
4	---	---
5	---	---
6	---	---
7	---	---
8	---	---

CONFIDENTIAL INFORMATION
 THESE DRAWING, SPECIFICATIONS AND OTHER INFORMATION AND DOCUMENTS ACCOMPANYING THEM ARE THE CONFIDENTIAL AND PROPRIETARY PROPERTY OF WAUSAU TILE, INC. THE DRAWINGS THEMSELVES SHALL BELONG TO THE OWNER FOR USE ONLY ON THE PROJECT. ANY ADDITIONAL USE SHALL REQUIRE THE PRIOR WRITTEN APPROVAL OF WAUSAU TILE, INC. THE PROPRIETARY INFORMATION CONTAINED WITHIN THE DRAWINGS AND THE DOCUMENTS IS AND SHALL REMAIN THE SOLE PROPERTY OF WAUSAU TILE, INC

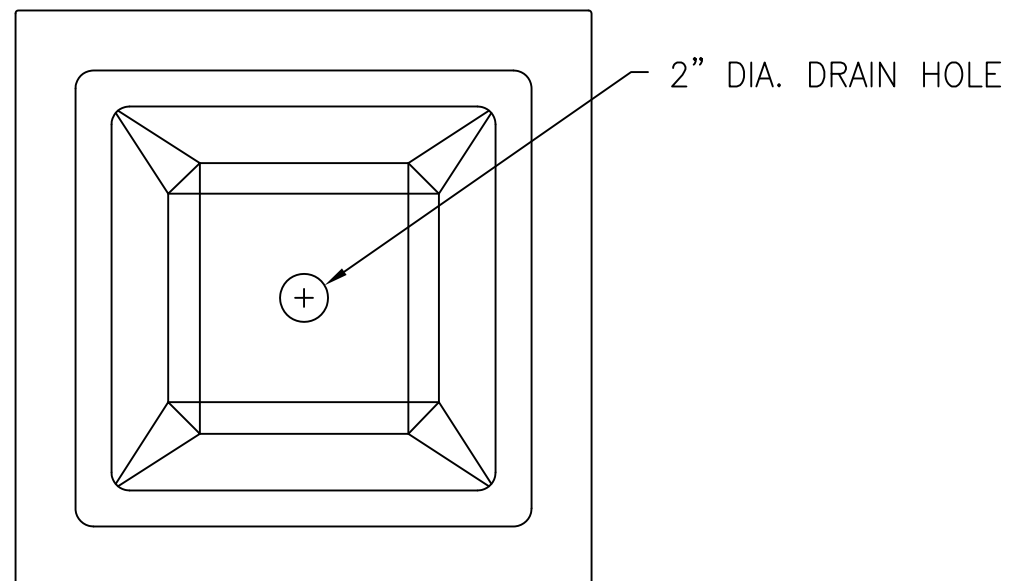

1 TOP VIEW

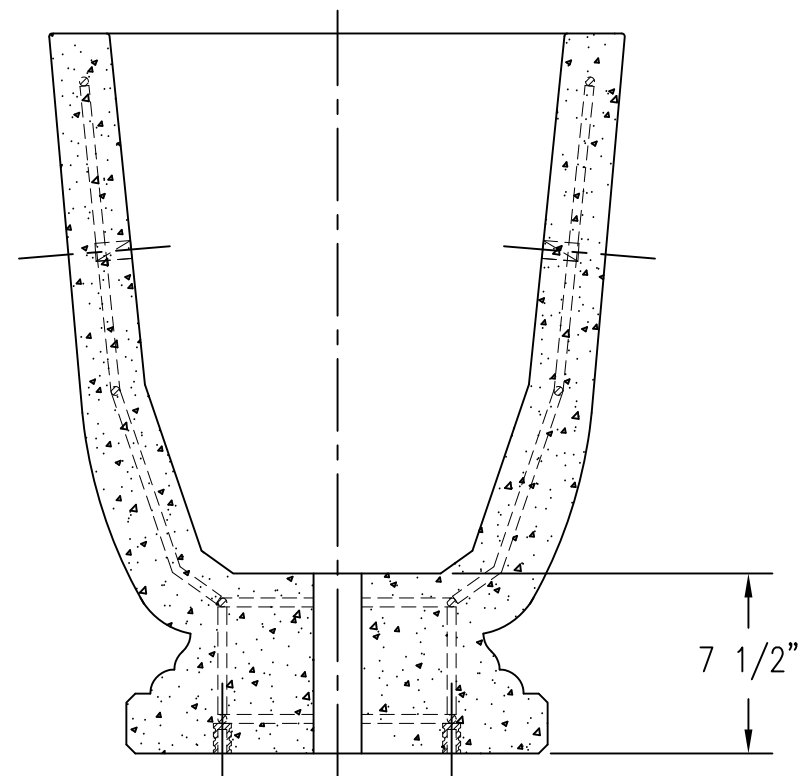

4 CROSS SECTION

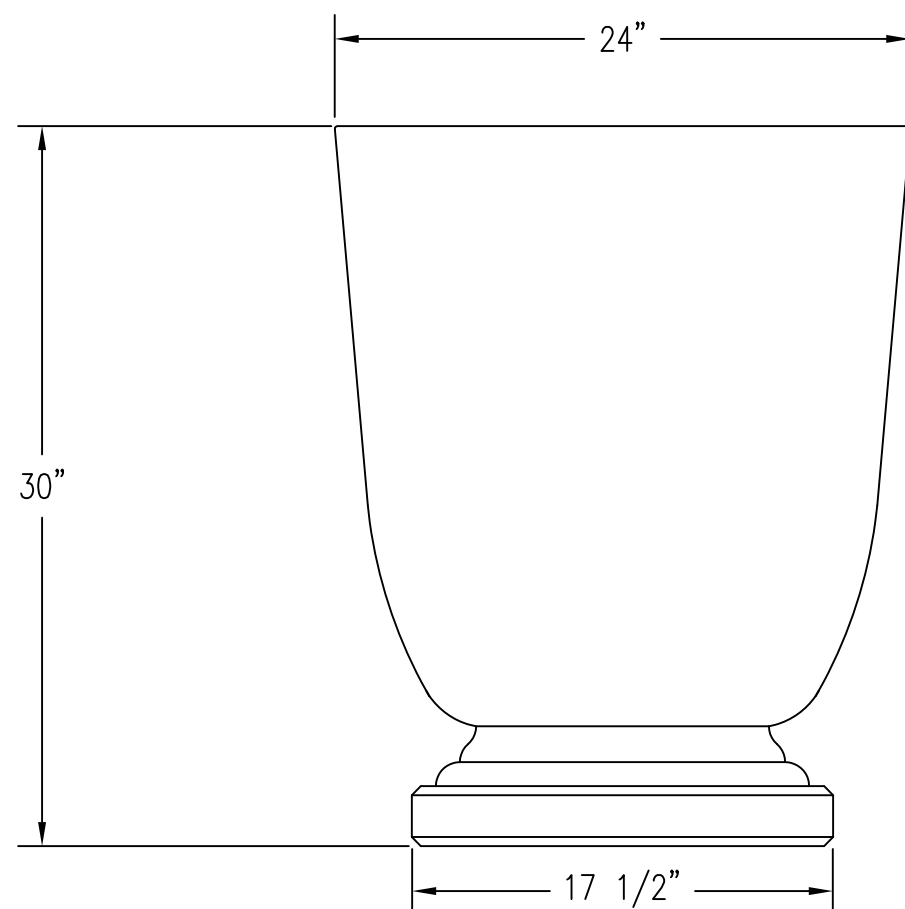

2 ELEVATION VIEW

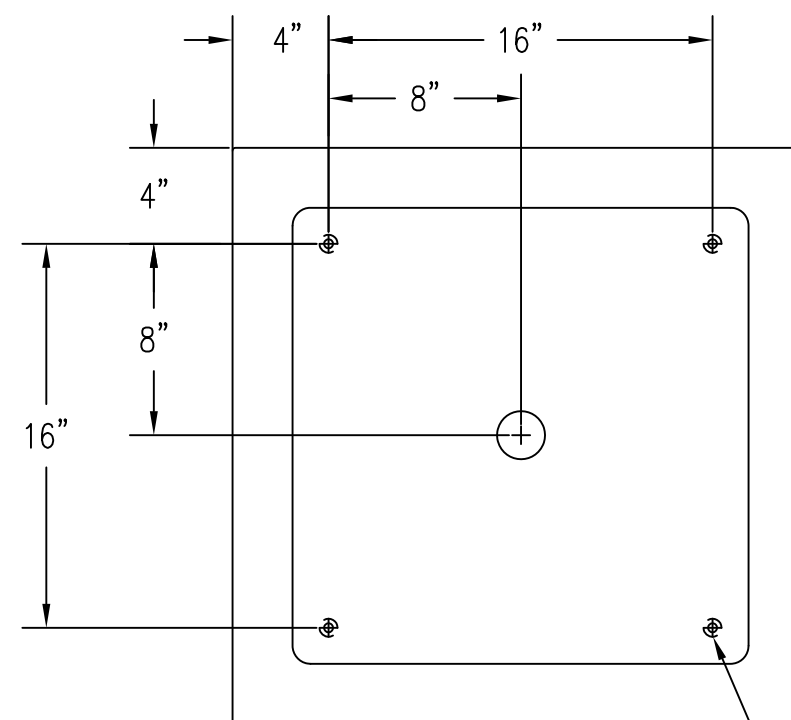

3 BOTTOM VIEW

(4) 3/8" UNC S/S INSERTS

JOB NAME
 ADDRESS
 CITY, STATE ZIP

UNLESS OTHERWISE SPECIFIED
 DIMENSIONS ARE IN INCHES
 FRACTIONS ±1/8"

DRAWN BY: TAS

DATE: 6/28/17

CO NUMBER: ?

WEIGHT: 520 LBS

PRODUCT NO.

WS450