

**REVISIONS**

NAME	DATE	NOTES
1	---	---
2	---	---
3	---	---
4	---	---
5	---	---
6	---	---
7	---	---
8	---	---

**CONFIDENTIAL INFORMATION**  
 THESE DRAWING, SPECIFICATIONS AND OTHER INFORMATION AND DOCUMENTS ACCOMPANYING THEM ARE THE CONFIDENTIAL AND PROPRIETARY PROPERTY OF WAUSAU TILE, INC. THE DRAWINGS THEMSELVES SHALL BELONG TO THE OWNER FOR USE ONLY ON THE PROJECT. ANY ADDITIONAL USE SHALL REQUIRE THE PRIOR WRITTEN APPROVAL OF WAUSAU TILE, INC. THE PROPRIETARY INFORMATION CONTAINED WITHIN THE DRAWINGS AND THE DOCUMENTS IS AND SHALL REMAIN THE SOLE PROPERTY OF WAUSAU TILE, INC.

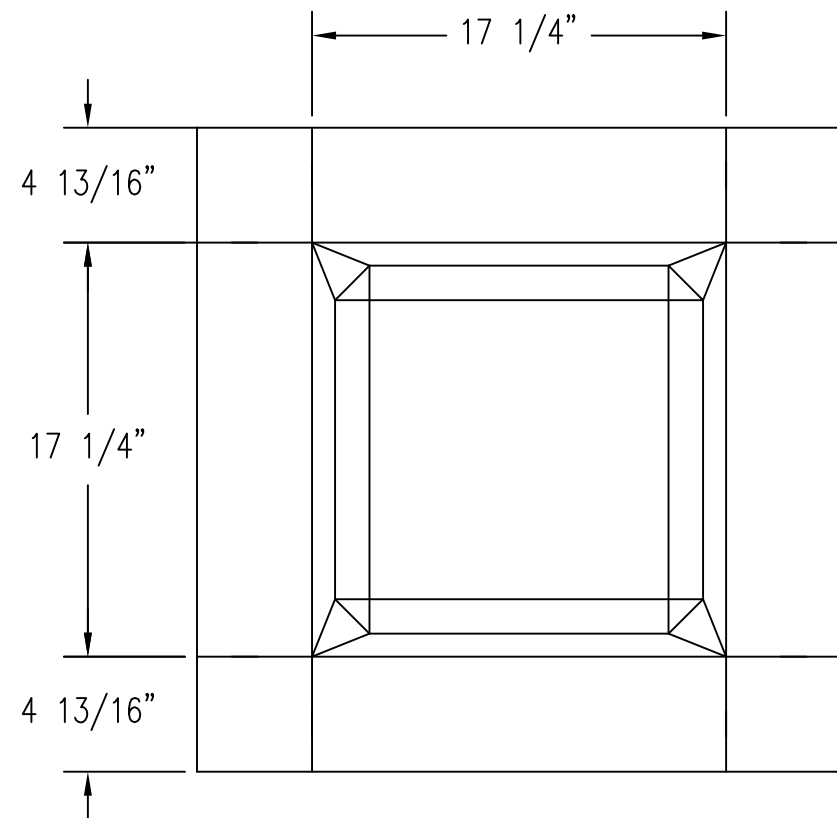

1 TOP VIEW

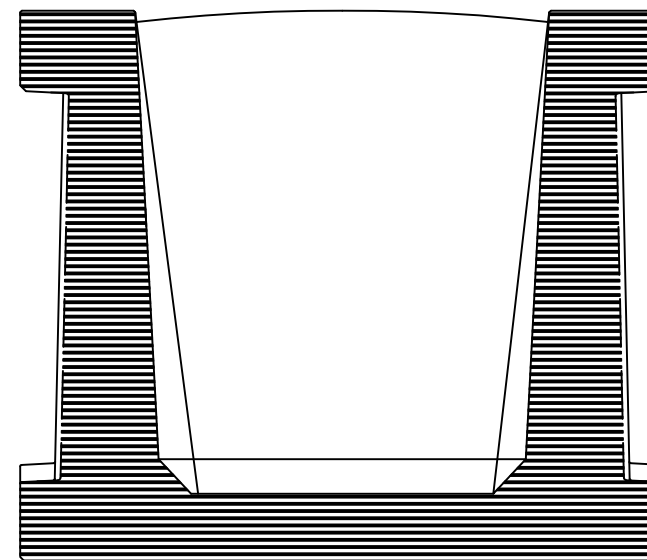

4 CROSS SECTION

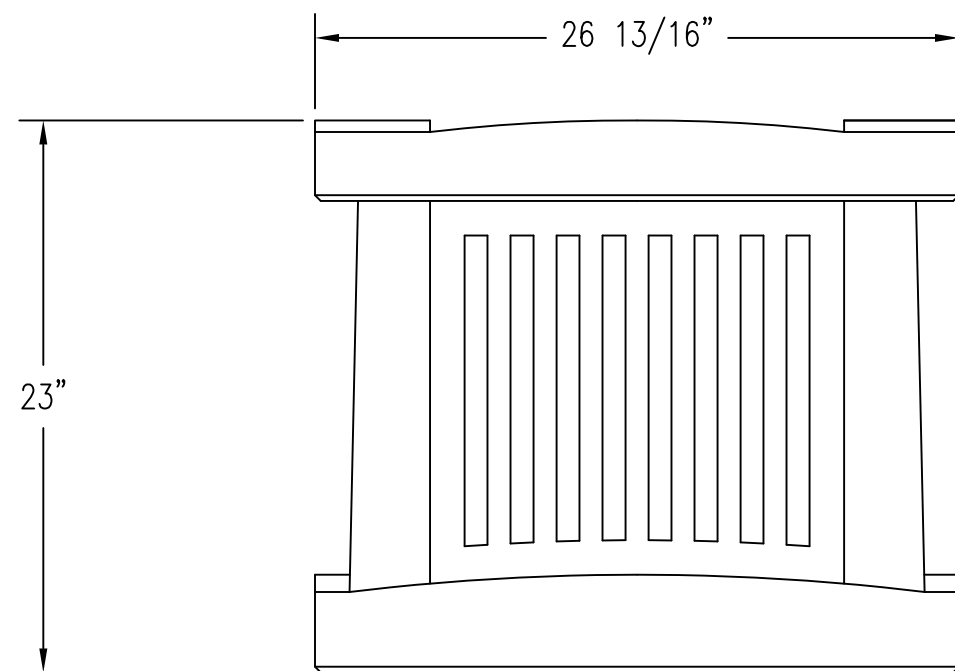

2 ELEVATION VIEW

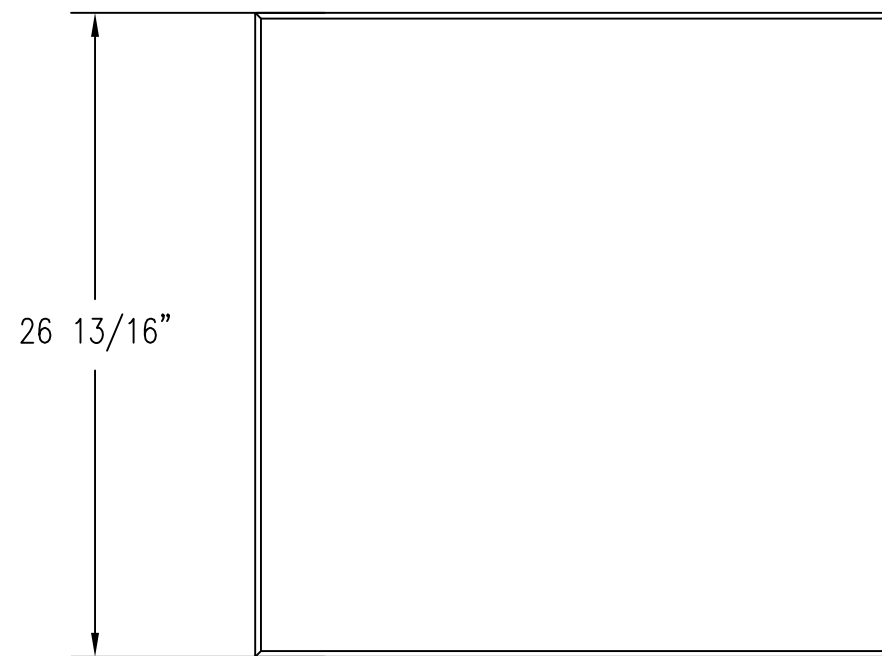

3 BOTTOM VIEW

JOB NAME

ADDRESS  
 CITY, STATE ZIP

UNLESS OTHERWISE SPECIFIED  
 DIMENSIONS ARE IN INCHES  
 FRACTIONS ±1/8"

DRAWN BY: TAS

DATE: 6/29/17

CO NUMBER: ?

WEIGHT: 30 LBS

PRODUCT NO.

WS4250