

REVISIONS

NAME	DATE	NOTES
1	---	---
2	---	---
3	---	---
4	---	---
5	---	---
6	---	---
7	---	---
8	---	---

CONFIDENTIAL INFORMATION
 THESE DRAWING, SPECIFICATIONS AND
 OTHER INFORMATION AND DOCUMENTS
 ACCOMPANYING THEM ARE THE
 CONFIDENTIAL AND PROPRIETARY PROPERTY
 OF WAUSAU TILE, INC. THE DRAWINGS
 THEMSELVES SHALL BELONG TO THE
 OWNER FOR USE ONLY ON THE PROJECT.
 ANY ADDITIONAL USE SHALL REQUIRE THE
 PRIOR WRITTEN APPROVAL OF WAUSAU
 TILE, INC. THE PROPRIETARY INFORMATION
 CONTAINED WITHIN THE DRAWINGS AND THE
 DOCUMENTS IS AND SHALL REMAIN THE
 SOLE PROPERTY OF WAUSAU TILE, INC

JOB NAME

WAUSAU, WI

UNLESS OTHERWISE SPECIFIED
 DIMENSIONS ARE IN INCHES
 FRACTIONS ± 1/8"

DRAWN BY: TAS

DATE: 6/30/17

CO NUMBER: ?

WEIGHT: 775 LBS

SHEET NO.

WS1010

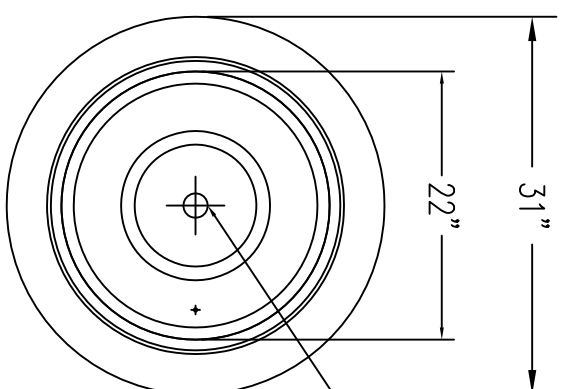

(1) 2" DIA. DRAIN HOLE

1

TOP VIEW

Scale: 1/16" = 1"

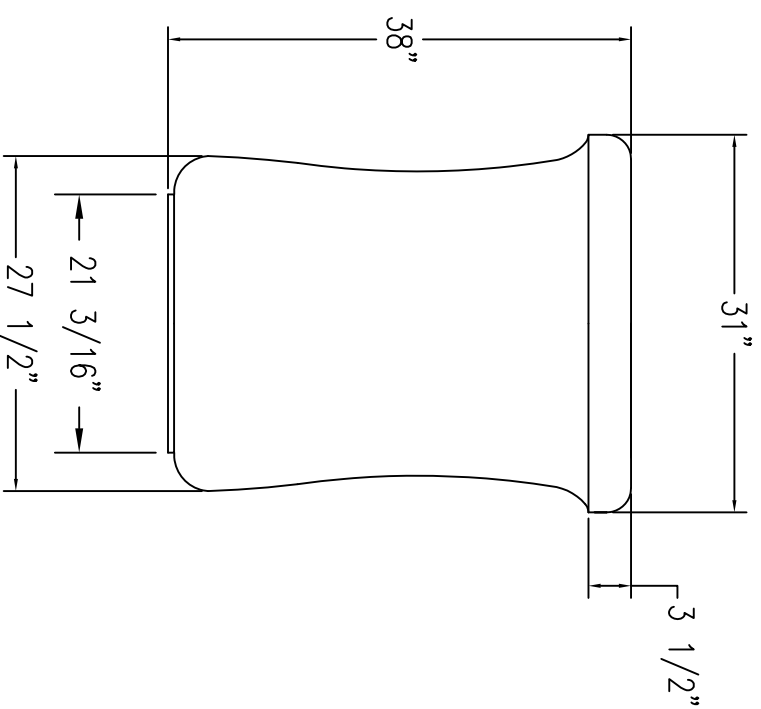

2

ELEVATION VIEW

Scale: 1/16" = 1"

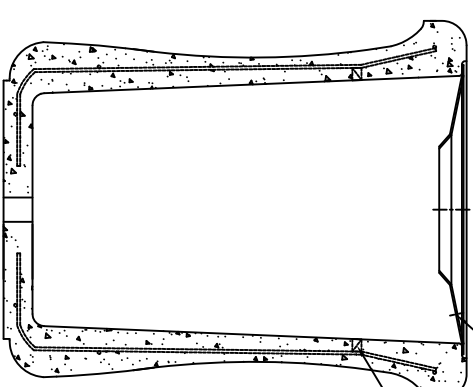

TF1515 ALUMINUM TOP

(2) 5/8" THREAD F44 INSERTS

1

TOP VIEW

Scale: 1/16" = 1"

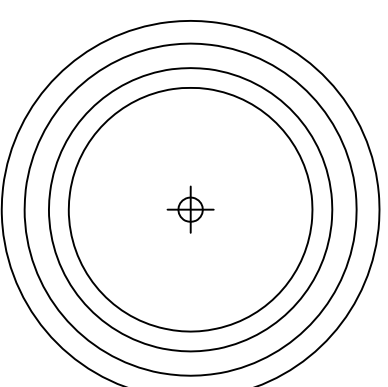

4

BOTTOM VIEW

Scale: 1/16" = 1"