

# TF7071

## Concrete Double Drinking Fountain

### Product Data

Size	48 3/8" x 21" x 34" h
Weight	780 lbs
Material	Reinforced Concrete (2) Spout (3) Access Panels (2) S.S. Bowl (2) Push Button
Reinforcing	Rebar
Anchoring	(4) 3/8" Threaded Inserts
Sealed	Factory Sealed
Drinking Bowl	9 3/4" dia x 1 7/8"/7" x 1 3/8"

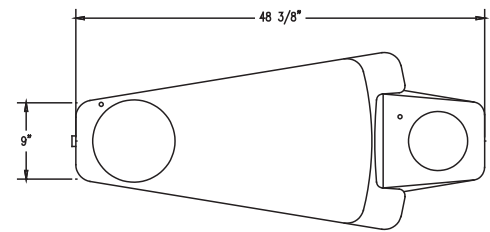

**BOTTOM VIEW**

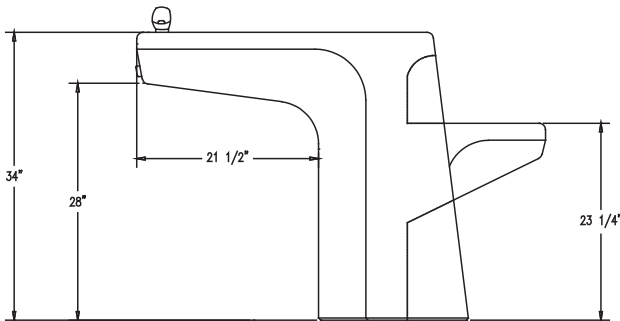

**ELEVATION VIEW**

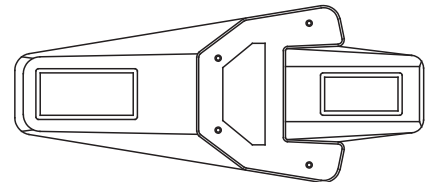

**TOP VIEW**

### Site Furnishings Limited Warranty:

For a period of two (2) years for concrete products, one (1) year for plastic products and five (5) years for metal products when the customer has received their product, Wausau Tile, Inc. warrants its concrete products against defects in workmanship and materials per industry standards. This warranty does not cover the above products for cracking and faulting caused by settling due to an improper base; nor does it cover damage caused by impact, vandalism or natural disaster.

**CALL FOR FURTHER DETAILS & PRICING.**

P: 800.388.8728 | E: [wtile@wausautile.com](mailto:wtile@wausautile.com) | [WAUSAUTILE.COM](http://WAUSAUTILE.COM)