



P.O. BOX 1520 WILKINS, WI 54402-1520
 800-388-6728
 E-MAIL: WILKINS@MAUSAUTILE.COM
 WEB SITE: WWW.MAUSAUTILE.COM

REVISIONS

NO.	NAME	DATE	NOTES
1			
2			
3			
4			
5			
6			
7			
8			

THESE DRAWING, SPECIFICATIONS AND OTHER INFORMATION ARE THE PROPERTY OF MAUSAU TILE, INC. THE DRAWINGS AND SPECIFICATIONS SHALL BELONG TO THE OWNER AND SHALL BE KEPT IN CONFIDENTIAL AND PROPRIETARY PROPERTY OF MAUSAU TILE, INC. ANY ADDITIONAL USE SHALL REQUIRE THE PRIOR WRITTEN APPROVAL OF MAUSAU TILE, INC. THE PROPRIETARY INFORMATION CONTAINED HEREIN IS THE SOLE PROPERTY OF MAUSAU TILE, INC.

JOB NAME
 ADDRESS
 CITY, STATE ZIP

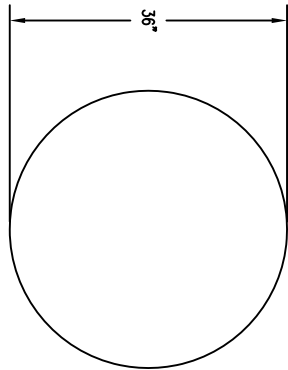

1 TOP VIEW

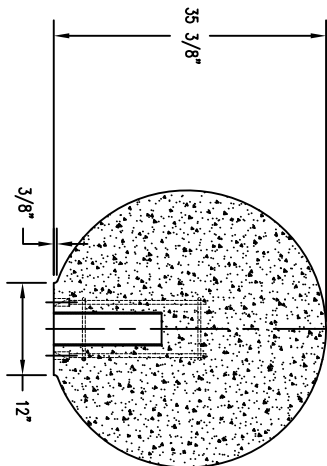

4 CROSS SECTION

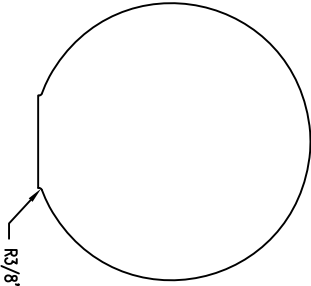

2 ELEVATION VIEW

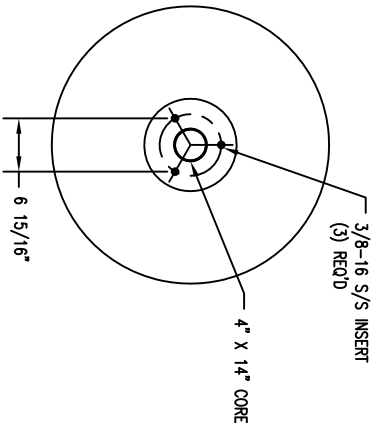

3 BOTTOM VIEW

UNLESS OTHERWISE SPECIFIED
 DIMENSIONS ARE IN INCHES
 FINISHES 4/16"

DRAWN BY: SK
 DATE: 6/8/15
 CD NUMBER: 7
 WEIGHT: 2.200 LBS

PRODUCT NO.
TF 6101