

REVISIONS		
NAME	DATE	NOTES
1	---	---
2	---	---
3	---	---
4	---	---
5	---	---
6	---	---
7	---	---
8	---	---

**CONFIDENTIAL INFORMATION**  
 THESE DRAWINGS, SPECIFICATIONS AND OTHER INFORMATION AND DOCUMENTS ACCOMPANYING THEM ARE THE CONFIDENTIAL AND PROPRIETARY PROPERTY OF WAUSAU TILE, INC. THE DRAWINGS THEMSELVES SHALL BELONG TO THE OWNER FOR USE ONLY ON THE PROJECT. ANY ADDITIONAL USE SHALL REQUIRE THE PRIOR WRITTEN APPROVAL OF WAUSAU TILE, INC. THE PROPRIETARY INFORMATION CONTAINED WITHIN THE DRAWINGS AND THE DOCUMENTS IS AND SHALL REMAIN THE SOLE PROPERTY OF WAUSAU TILE, INC.

JOB NAME \_\_\_\_\_  
 ADDRESS \_\_\_\_\_  
 CITY, STATE ZIP \_\_\_\_\_

UNLESS OTHERWISE SPECIFIED  
 DIMENSIONS ARE IN INCHES  
 FRACTIONS ±1/8"

DRAWN BY: SK
DATE: 6/18/15
CO NUMBER: ?
WEIGHT: 360 LBS

PRODUCT NO.  
**TF 6086**

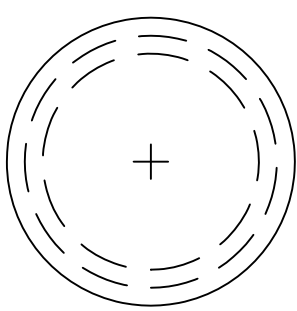

1 TOP VIEW

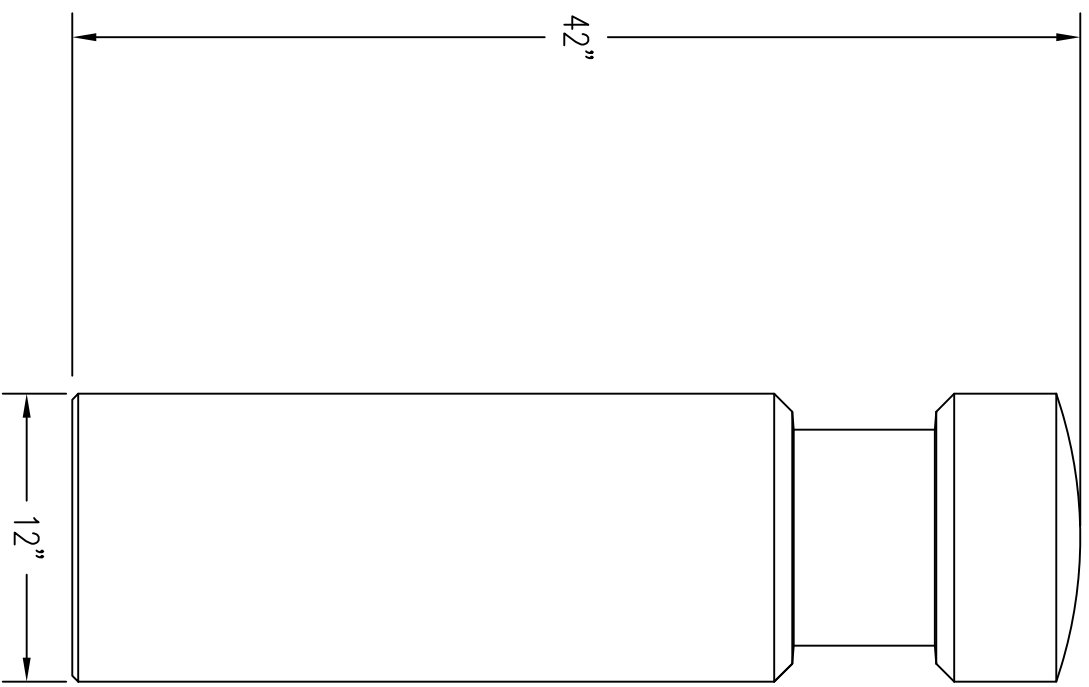

2 ELEVATION VIEW

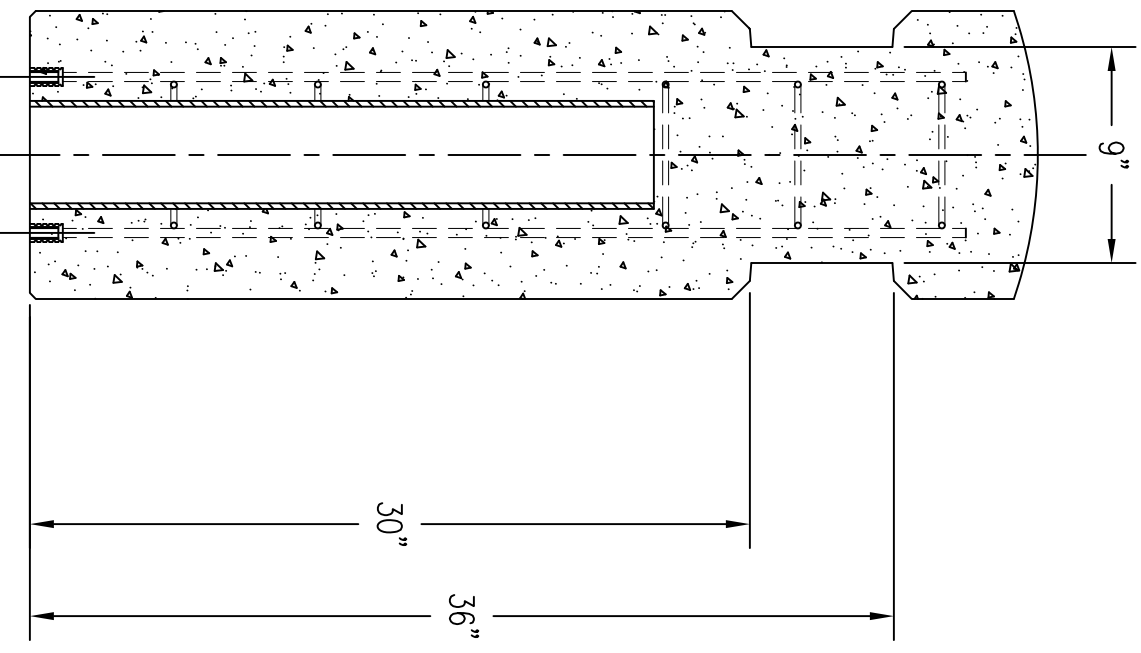

4 CROSS SECTION

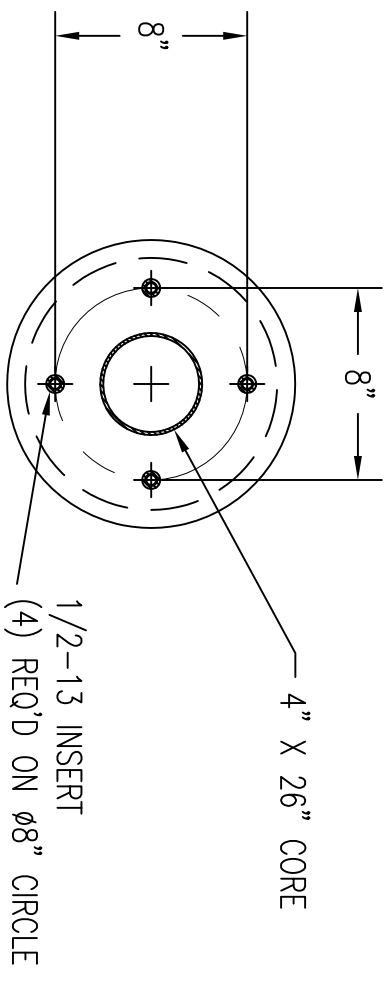

3 BOTTOM VIEW