



WAUSAU TILE

P.O. BOX 1520 WAUSAU, WI 54402-1520
800-388-8728
E-MAIL: WTILE@WAUSAUTILE.COM
WEBSITE: WWW.WAUSAUTILE.COM

REVISIONS

	BY	DATE	NOTES
1			
2			
3			
4			
5			
6			

CONFIDENTIAL INFORMATION
THESE DRAWING, SPECIFICATIONS AND OTHER INFORMATION AND DOCUMENTS ACCOMPANYING THEM ARE THE CONFIDENTIAL AND PROPRIETARY PROPERTY OF WAUSAU TILE, INC. THE DRAWINGS THEMSELVES SHALL BELONG TO THE OWNER FOR USE ONLY ON THE PROJECT. ANY ADDITIONAL USE SHALL REQUIRE THE PRIOR WRITTEN APPROVAL OF WAUSAU TILE, INC. THE PROPRIETARY INFORMATION CONTAINED WITHIN THE DRAWINGS AND THE DOCUMENTS IS AND SHALL REMAIN THE SOLE PROPERTY OF WAUSAU TILE, INC.

UNLESS OTHERWISE SPECIFIED DIMENSIONS SHOWN ARE ROUNDED TO THE CLOSEST FRACTION + 1/16"

DRAWING SCALE: NOT TO SCALE

FABRICATION TOLERANCE: ± 1/8"

WAUSAU TILE INC. WAUSAU, WI BENCH

CUSTOMER SIGNATURE REQUIRED

APPROVED: _____

DATE: _____

(SIGNATURE ABOVE ILLUSTRATES YOU HAVE REVIEWED ALL ASPECTS OF THE DESIGN FOR ACCURACY AND COMPLIANCE WITH YOUR JOB REQUIREMENTS AND APPROVE FABRICATION AS REPRESENTED WITHIN THESE DRAWINGS)

DRAWN BY: WT | PROJ MNGR: X

DATE: 5/18/21

CO NUMBER: X

REFERENCE: TF5076

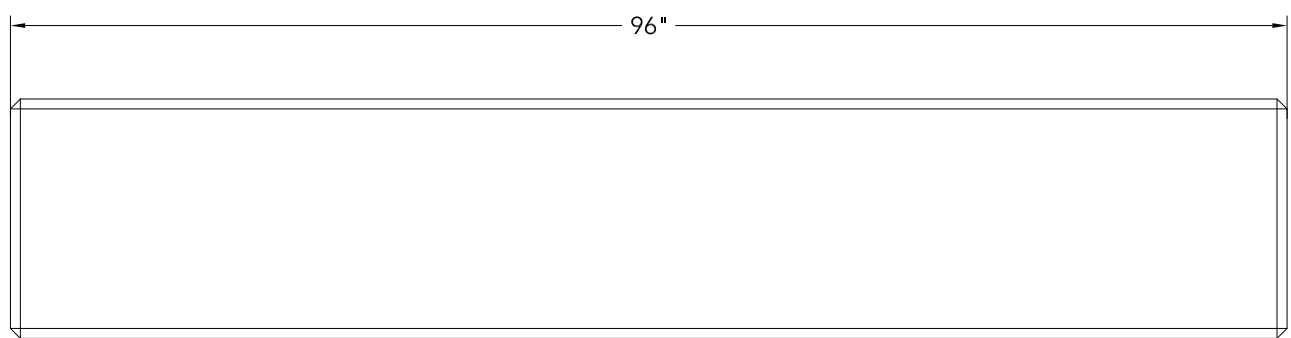

1 TOP VIEW

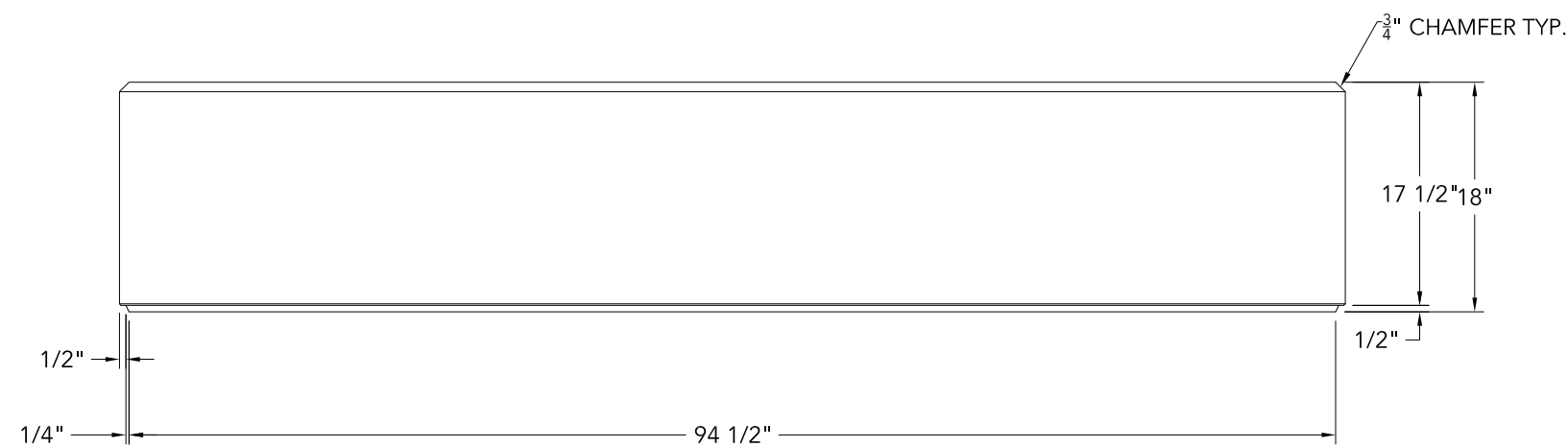

2 FRONT & BACK VIEW

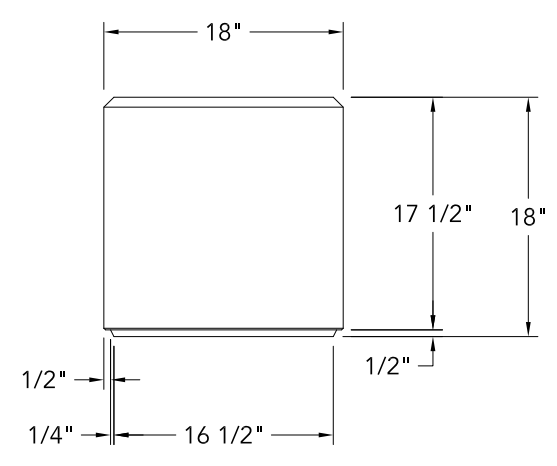

4 END VIEW

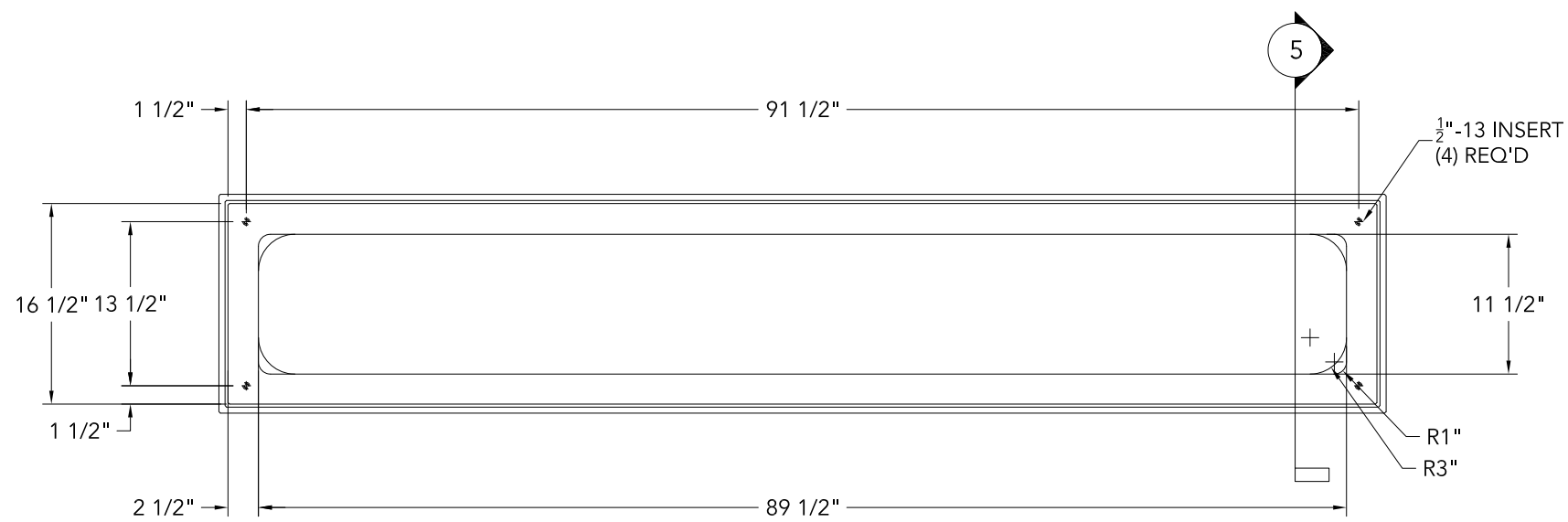

3 BOTTOM VIEW

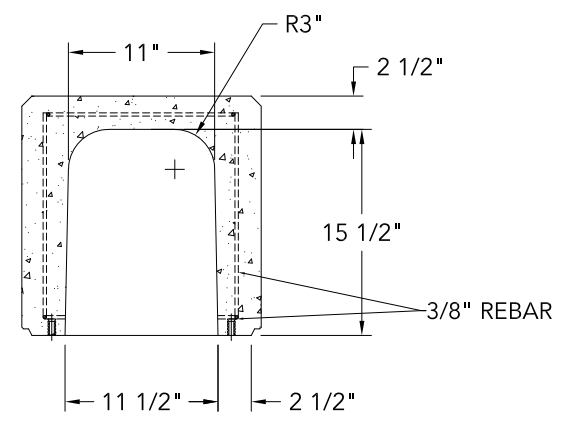

5 SECTION VIEW

