



P.O. BOX 1520 WAUSAU, WI 54402-1520
 E-MAIL: SALES@WAUSAUTILE.COM
 WEB SITE: WWW.WAUSAUTILE.COM

REVISIONS

NAME	DATE	NOTES
1		
2		
3		
4		
5		
6		
7		
8		

THESE DRAWING SPECIFICATIONS AND OTHER INFORMATION AND ACCOMPANYING THEM ARE THE CONFIDENTIAL AND PROPRIETARY PROPERTY OF WAUSAU TILE, INC. THE DRAWINGS HEREIN SHALL BELONG TO THE OWNER AND SHALL BE KEPT IN STRICTLY CONFIDENTIAL. NO PART OF ANY ADDITIONAL USE SHALL REQUIRE THE PRIOR WRITTEN APPROVAL OF WAUSAU TILE, INC. THE PROPRIETARY INFORMATION CONTAINED WITHIN THE DRAWINGS AND THIS DOCUMENT IS THE PROPERTY OF WAUSAU TILE, INC. THE SITE PROPERTY OF WAUSAU TILE, INC.

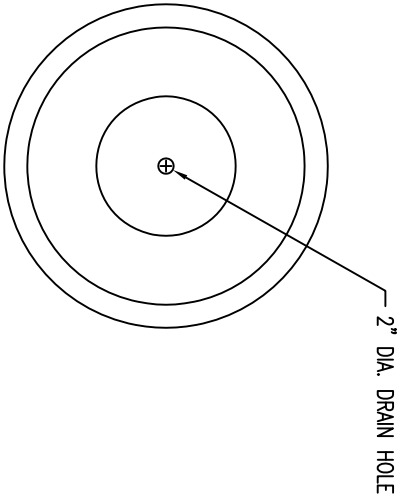

1 TOP VIEW

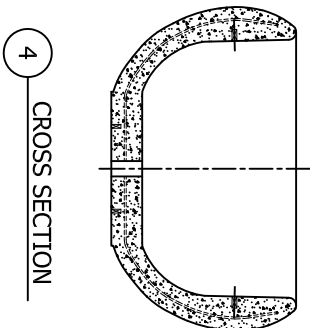

4 CROSS SECTION

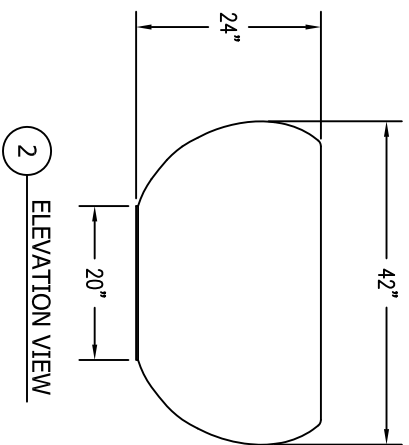

2 ELEVATION VIEW

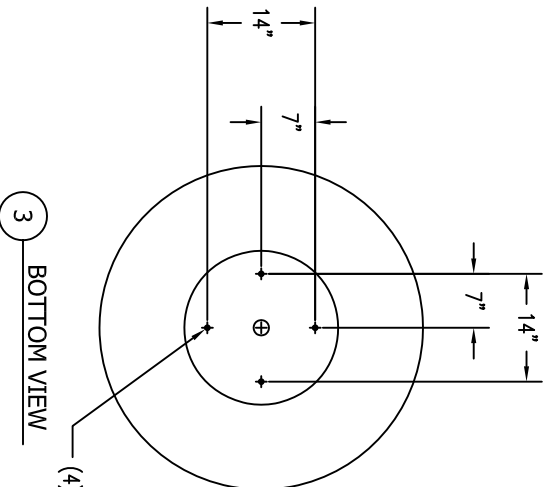

3 BOTTOM VIEW

(4) 1/2"-13 UNC S/S INSERTS

JOB NAME
 ADDRESS
 CITY, STATE ZIP

UNLESS OTHERWISE SPECIFIED
 DIMENSIONS ARE IN INCHES
 FINISHES 4/16"

DRAWN BY: SK
 DATE: 7/14/15
 CD NUMBER: F
 WEIGHT: 1,000 LBS

PRODUCT NO.
TF 4353