

2" DRAIN HOLE

1 TOP VIEW

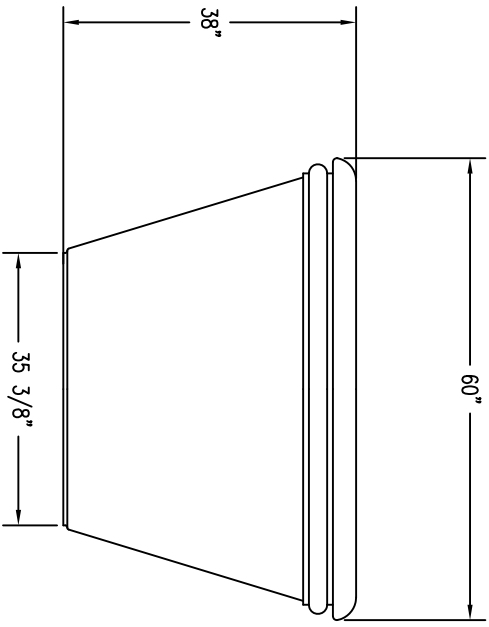

2 ELEVATION VIEW

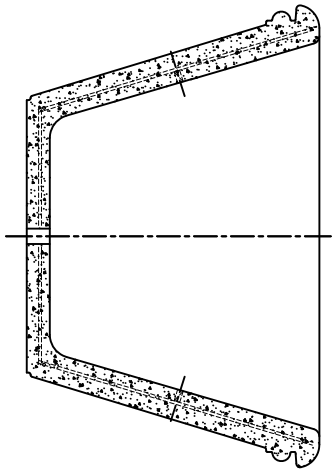

4 CROSS SECTION

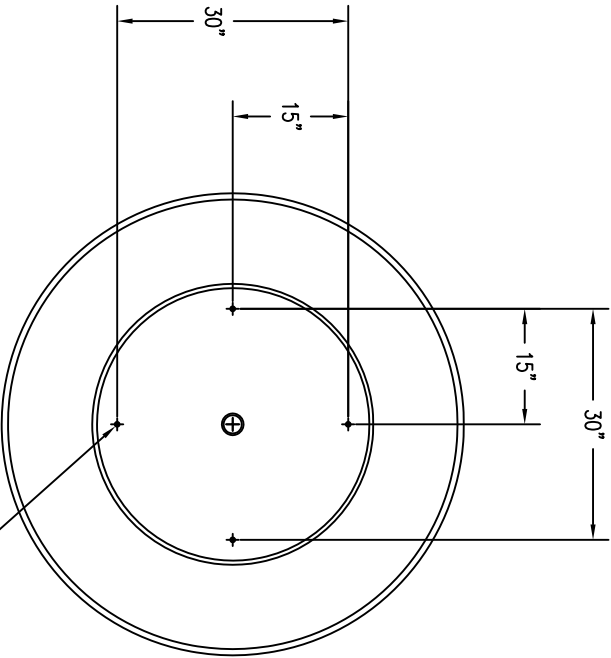

3 BOTTOM VIEW
(4) 1/2-13 INSERTS

P.O. BOX 1520 WAUSAU, WI 54402-1520
E-MAIL: WATERMAN@TILE.COM
WEB SITE: WWW.WATERMANTILE.COM



REVISIONS

NAME	DATE	NOTES
1		
2		
3		
4		
5		
6		
7		
8		

THESE DRAWING, SPECIFICATIONS AND OTHER INFORMATION ARE THE PROPERTY OF WAUSAU TILE, INC. THE DRAWINGS, SPECIFICATIONS AND OTHER INFORMATION SHALL REMAIN THE PROPERTY OF WAUSAU TILE, INC. ANY ADDITIONAL USE SHALL REQUIRE THE PRIOR WRITTEN APPROVAL OF WAUSAU TILE, INC. THE PROPRIETARY INFORMATION AND TRADE SECRETS OF WAUSAU TILE, INC. SHALL REMAIN THE SOLE PROPERTY OF WAUSAU TILE, INC.

JOB NAME

ADDRESS
CITY, STATE ZIP

UNLESS OTHERWISE SPECIFIED
DIMENSIONS ARE IN INCHES
FRACTIONS 1/8"

DRAWN BY: SK
DATE: 7/24/15
CD NUMBER: 7
WEIGHT: 2.015 LBS

PRODUCT NO.

TF 4305