



P.O. BOX 1520 WILKINSON, WI 54402-1520
 800-388-6728
 E-MAIL: WILKINSON@MAUSAUTILE.COM
 WEB SITE: WWW.MAUSAUTILE.COM

REVISIONS

NO.	NAME	DATE	NOTES
1			
2			
3			
4			
5			
6			
7			
8			

CONFIDENTIAL INFORMATION
 THESE DRAWINGS, SPECIFICATIONS AND
 OTHER DOCUMENTS ARE THE PROPERTY
 OF MAUSAU TILE, INC. THE DRAWINGS
 AND SPECIFICATIONS SHALL BE THE
 PROPERTY OF MAUSAU TILE, INC. THE
 OWNER SHALL BE RESPONSIBLE FOR
 ANY ADDITIONAL USE SHALL REQUIRE THE
 PRIOR WRITTEN APPROVAL OF MAUSAU
 TILE, INC. THE PROPRIETARY INFORMATION
 CONTAINED HEREIN IS THE PROPERTY OF
 MAUSAU TILE, INC. AND SHALL REMAIN
 THE SOLE PROPERTY OF MAUSAU TILE, INC.

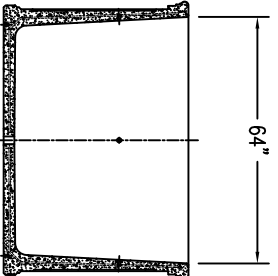

4 CROSS SECTION

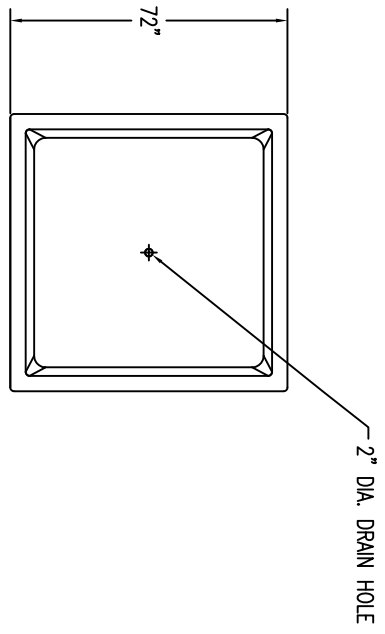

1 TOP VIEW

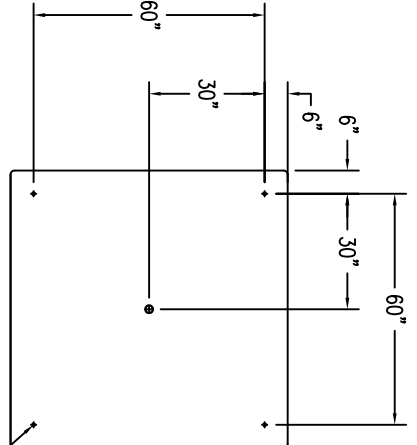

3 BOTTOM VIEW

(4) 1/2" UNC S/S INSERTS

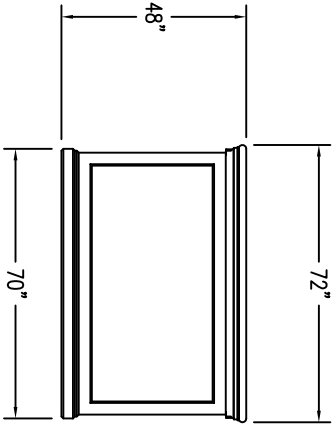

2 ELEVATION VIEW

JOB NAME
 ADDRESS
 CITY, STATE ZIP

UNLESS OTHERWISE SPECIFIED
 DIMENSIONS ARE IN INCHES
 FINISHES 1/8"

DRAWN BY: SK
 DATE: 7/22/15
 CD NUMBER: 7
 WEIGHT: 4.620 LBS

PRODUCT NO.
 TF 4243