

REVISIONS

| NAME | DATE | NOTES |
|------|------|-------|
| 1 | | |
| 2 | | |
| 3 | | |
| 4 | | |
| 5 | | |
| 6 | | |
| 7 | | |
| 8 | | |

THESE DRAWING, SPECIFICATIONS AND OTHER INFORMATION ARE THE PROPERTY OF MAUSAU TILE, INC. THE DRAWINGS AND SPECIFICATIONS SHALL BELONG TO THE OWNER AND SHALL REMAIN THE PROPERTY OF MAUSAU TILE, INC. THE PROPRIETARY INFORMATION CONTAINED HEREIN IS UNCLASSIFIED AND IS THE SOLE PROPERTY OF MAUSAU TILE, INC.

JOB NAME _____
 ADDRESS _____
 CITY, STATE ZIP _____

UNLESS OTHERWISE SPECIFIED
 DIMENSIONS ARE IN INCHES
 FINISHES 4/16"

DRAWN BY: SK
 DATE: 7/22/15
 CD NUMBER: 7
 WEIGHT: 945 LBS
 PRODUCT NO.
TF 4240

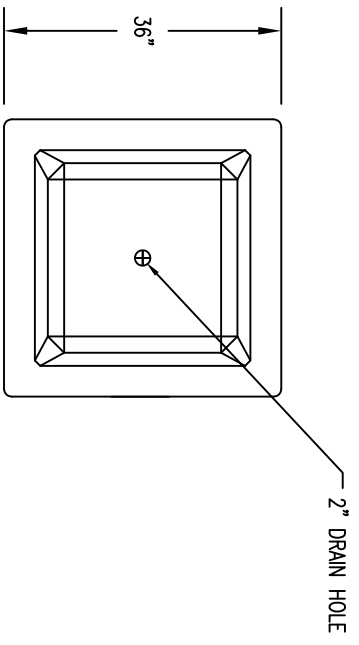

1 TOP VIEW

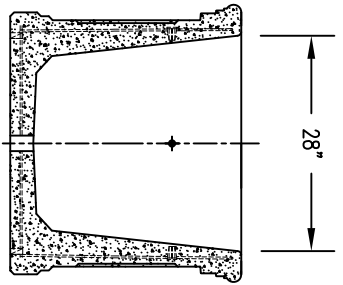

4 CROSS SECTION

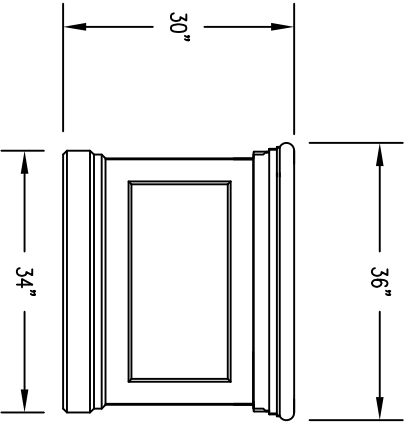

2 ELEVATION VIEW

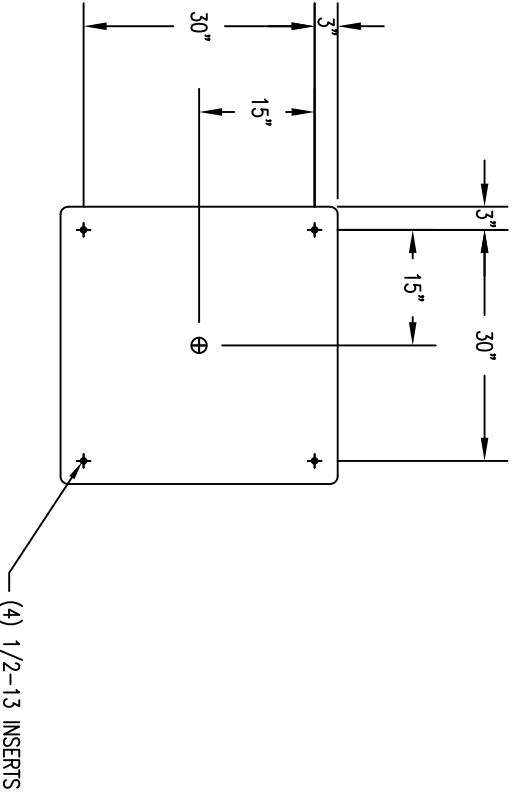

3 BOTTOM VIEW