

2" DIA. DRAIN HOLE

1 TOP VIEW

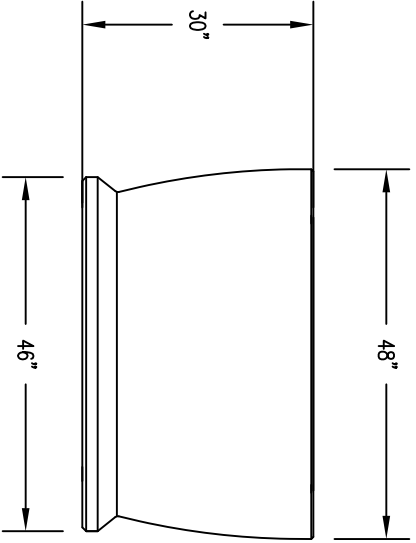

2 ELEVATION VIEW

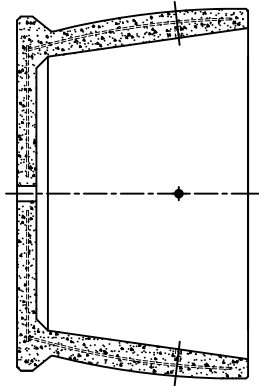

4 CROSS SECTION

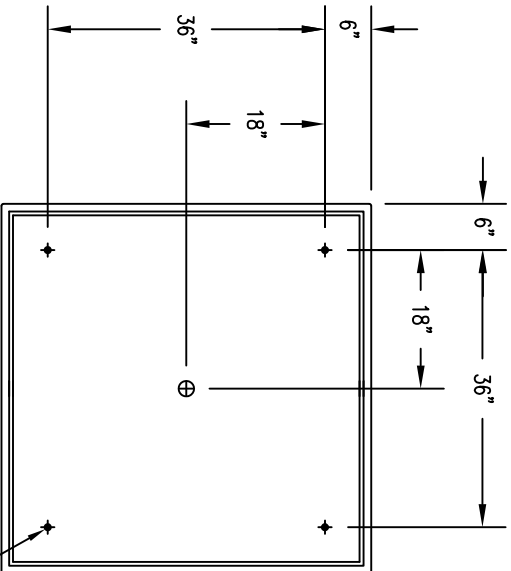

3 BOTTOM VIEW

(4) 1/2-13 INSERTS

P.O. BOX 1520 WISAU, WI 54402-1520
 E-MAIL: WATERMAN@TILE.COM
 WEB SITE: WWW.WATERMANTILE.COM



REVISIONS

NAME	DATE	NOTES
1		
2		
3		
4		
5		
6		
7		
8		

THESE DRAWING, SPECIFICATIONS AND OTHER INFORMATION ARE THE PROPERTY OF WASAU TILE, INC. THE DRAWINGS AND SPECIFICATIONS SHALL REMAIN THE PROPERTY OF WASAU TILE, INC. ANY ADDITIONAL USE SHALL REQUIRE THE PRIOR WRITTEN APPROVAL OF WASAU TILE, INC. THE PROPRIETARY INFORMATION AND TRADE SECRETS OF WASAU TILE, INC. SHALL REMAIN THE PROPERTY OF WASAU TILE, INC.

JOB NAME
 ADDRESS
 CITY, STATE ZIP

UNLESS OTHERWISE SPECIFIED
 DIMENSIONS ARE IN
 INCHES ±1/8"

DRAWN BY: SK
 DATE: 8/11/15
 CD NUMBER: 7
 WEIGHT: 1.990 LBS

PRODUCT NO.
 TF 4204