



P.O. BOX 1520 WISAU, WI 54402-1520
 E-MAIL: WATERMAN@MASAU.COM
 WEB SITE: WWW.MASAU.COM

REVISIONS		
NAME	DATE	NOTES
1		
2		
3		
4		
5		
6		
7		
8		

THESE DRAWING SPECIFICATIONS AND OTHER INFORMATION ARE THE CONFIDENTIAL AND PROPRIETARY PROPERTY OF MASAU TILE, INC. THE DRAWINGS HEREIN SHALL BELONG TO THE OWNER OF THE PROJECT AND SHALL NOT BE REPRODUCED OR USED FOR ANY OTHER PROJECT WITHOUT THE WRITTEN APPROVAL OF MASAU TILE, INC. THE PROPRIETARY INFORMATION CONTAINED HEREIN IS UNCLASSIFIED AND IS THE SOLE PROPERTY OF MASAU TILE, INC.

JOB NAME
 ADDRESS
 CITY, STATE ZIP

UNLESS OTHERWISE SPECIFIED
 DIMENSIONS ARE IN INCHES
 FINISHES 4 1/8"

DRAWN BY: SK
 DATE: 8/11/15
 CD NUMBER: 7
 WEIGHT: 300 LBS

PRODUCT NO.
TF 4149

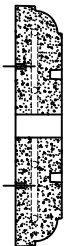

4 CROSS SECTION

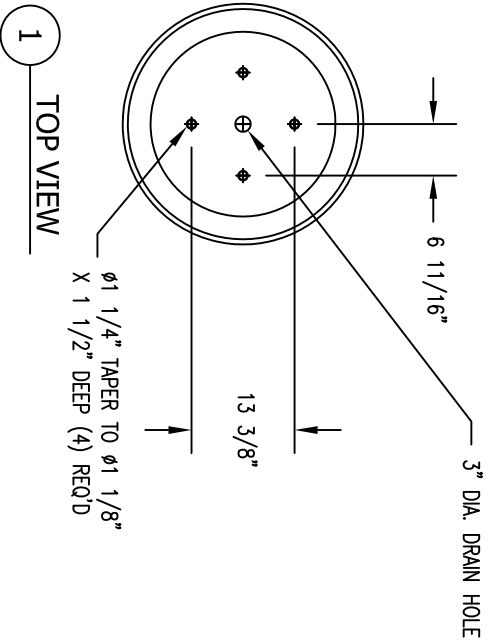

1 TOP VIEW

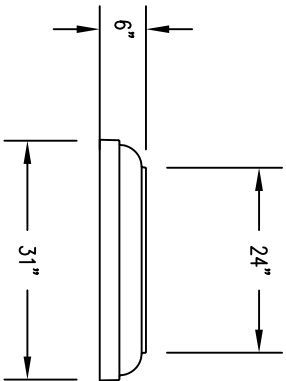

2 ELEVATION VIEW

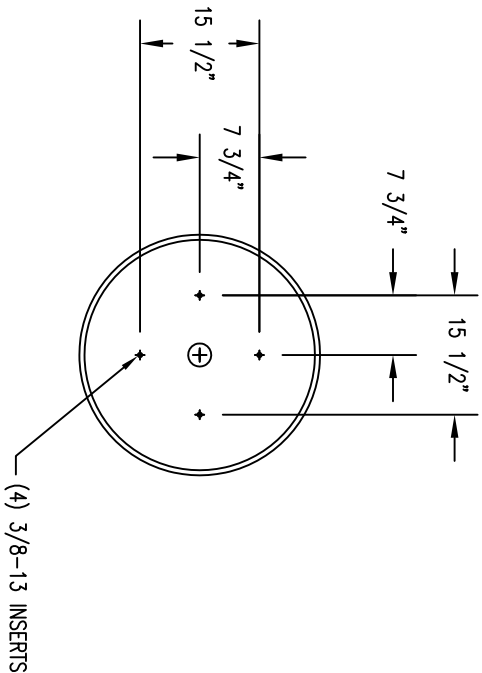

3 BOTTOM VIEW