

TF4133

Planter

Product Data

Size	60" Dia. x 18" H
Weight	1200 lbs
Material	Reinforced Concrete
Reinforcing	3/8" Dia. steel rebar
Drain Hole	(1) 2" Dia.
F pbu pc	1 g ,gdrglegl cpr

Lmrc

gdrglegl cpr pcrn L W c
s cbufcln lrcpg N W

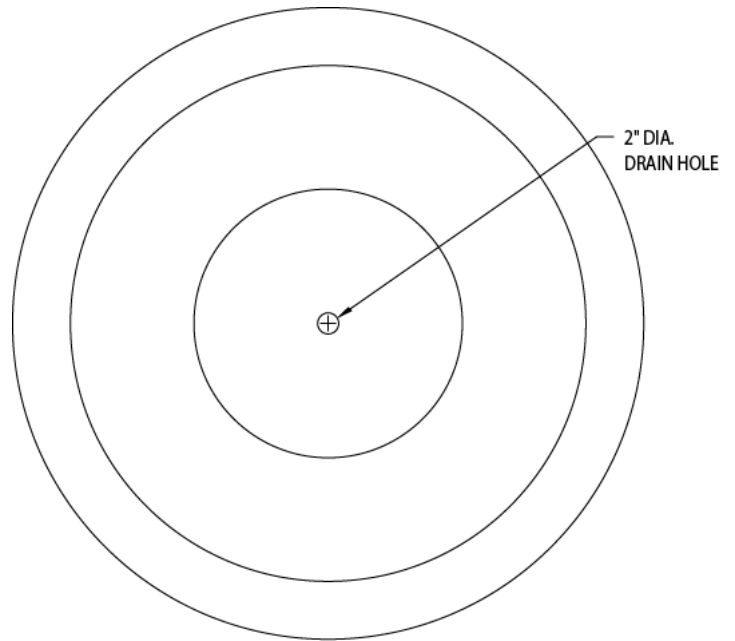

TOP VIEW

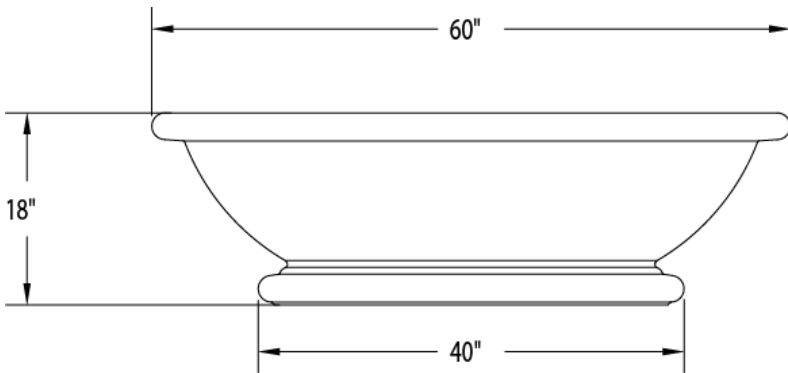

ELEVATION VIEW

Site Furnishings Limited Warranty:

For a period of two (2) years for concrete products, one (1) year for plastic products and five (5) years for metal products when the customer has received their product, Wausau Tile, Inc. warrants its concrete products against defects in workmanship and materials per industry standards. This warranty does not cover the above products for cracking and faulting caused by settling due to an improper base; nor does it cover damage caused by impact, vandalism or natural disaster.

CALL FOR FURTHER DETAILS & PRICING.

P: 800.388.8728 | E: wtile@wausautile.com | WAUSAUTILE.COM