

| REVISIONS |      |       |
|-----------|------|-------|
| NAME      | DATE | NOTES |
| 1         | ---  | ---   |
| 2         | ---  | ---   |
| 3         | ---  | ---   |
| 4         | ---  | ---   |
| 5         | ---  | ---   |
| 6         | ---  | ---   |
| 7         | ---  | ---   |
| 8         | ---  | ---   |

CONFIDENTIAL INFORMATION  
 THESE DRAWINGS, SPECIFICATIONS AND  
 OTHER INFORMATION AND DOCUMENTS  
 ACCOMPANYING THEM ARE THE  
 CONFIDENTIAL AND PROPRIETARY PROPERTY  
 OF WAUSAU TILE, INC. THE DRAWINGS  
 THEMSELVES SHALL BELONG TO THE  
 OWNER FOR USE ONLY ON THE PROJECT.  
 ANY ADDITIONAL USE SHALL REQUIRE THE  
 PRIOR WRITTEN APPROVAL OF WAUSAU  
 TILE, INC. THE PROPRIETARY INFORMATION  
 CONTAINED WITHIN THE DRAWINGS AND  
 THE DOCUMENTS IS AND SHALL REMAIN  
 THE SOLE PROPERTY OF WAUSAU TILE, INC.

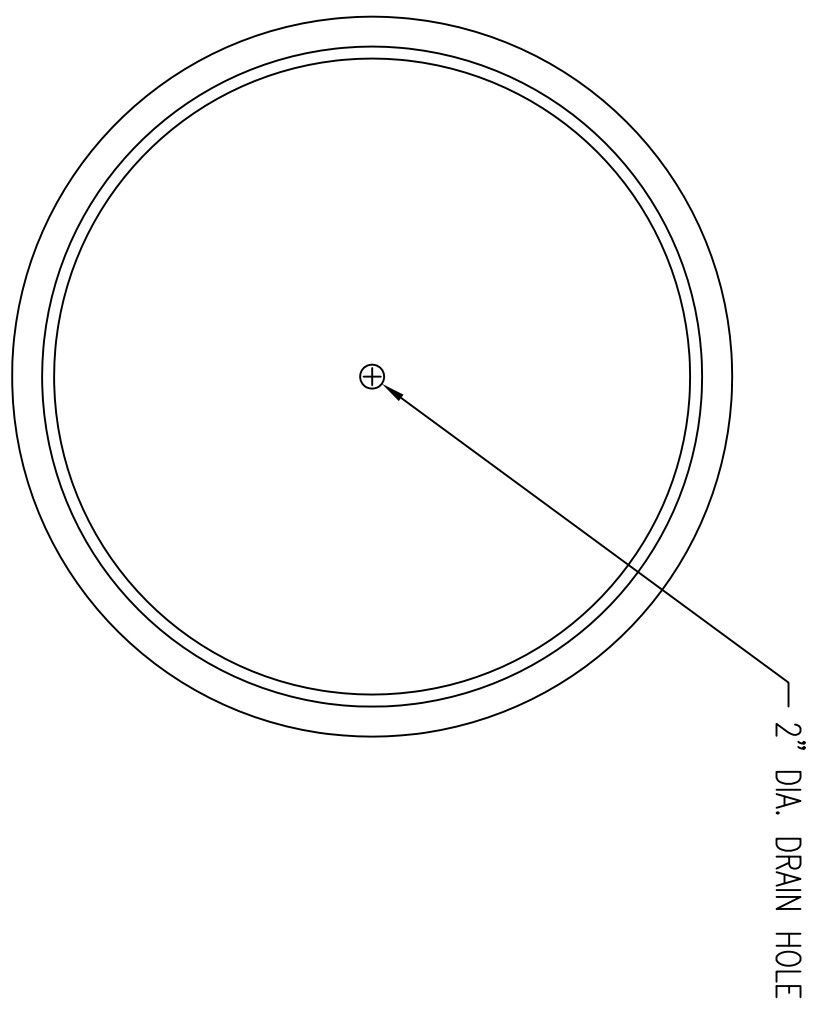

1 TOP VIEW

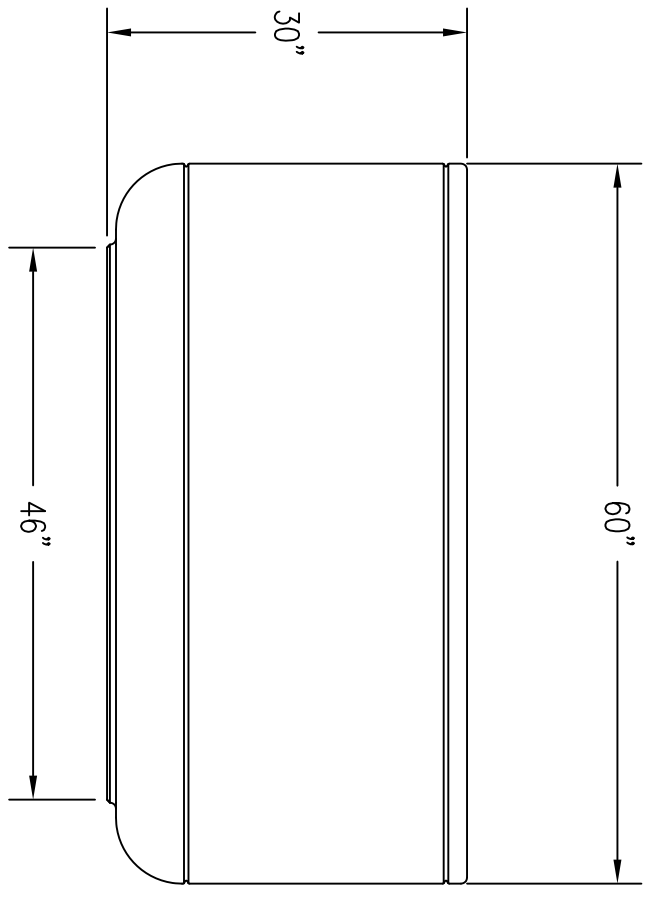

2 ELEVATION VIEW

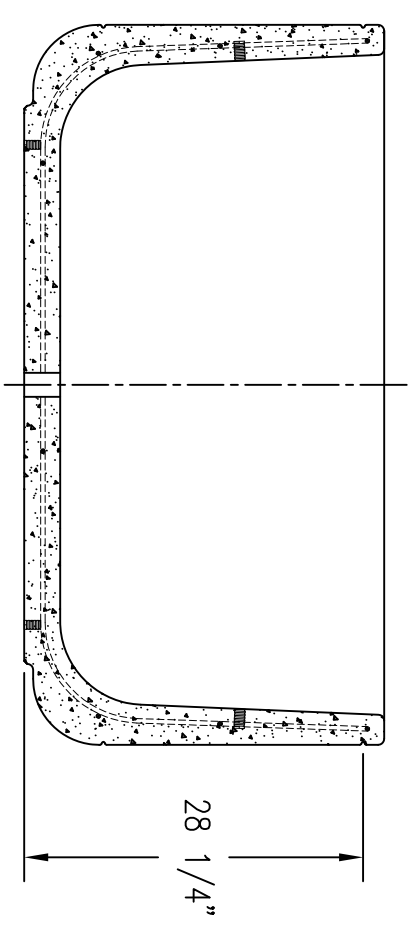

4 CROSS SECTION

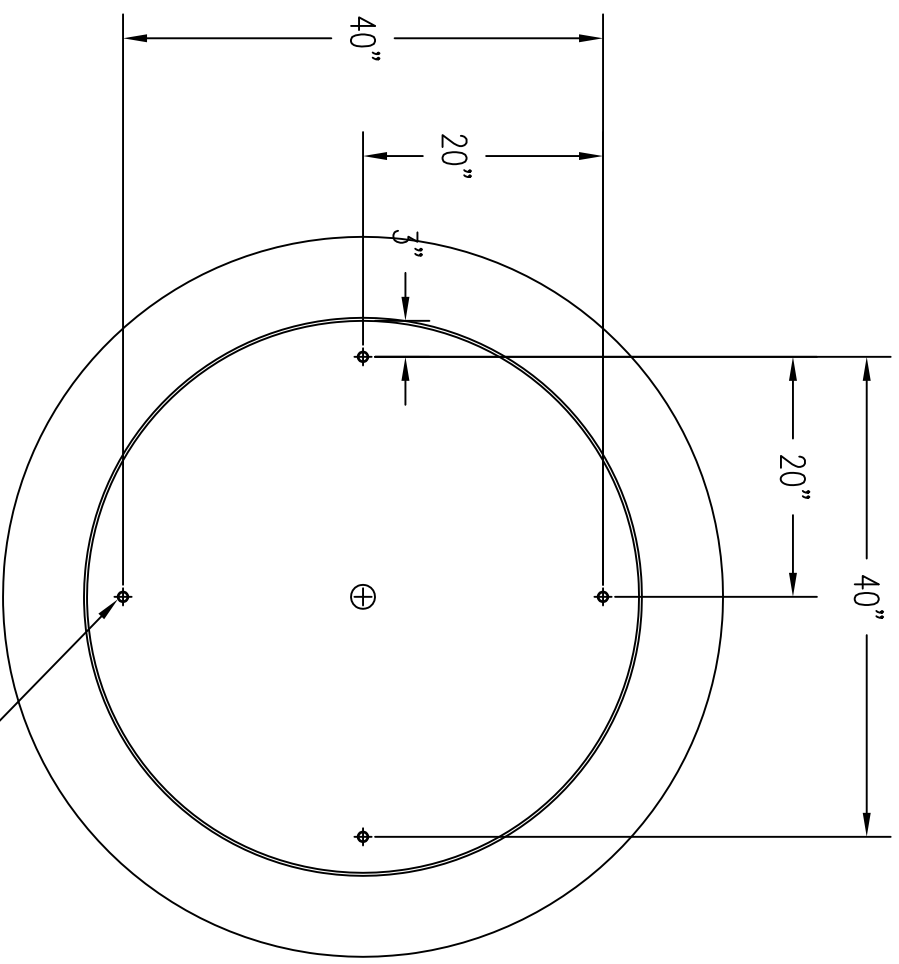

3 BOTTOM VIEW (4) 1/2 - 13 INSERTS

JOB NAME  
 ADDRESS  
 CITY, STATE ZIP

UNLESS OTHERWISE SPECIFIED  
 DIMENSIONS ARE IN INCHES  
 FRACTIONS ±1/8"

DRAWN BY: SK  
 DATE: 7/7/15  
 CO NUMBER: ?  
 WEIGHT: 2,200 LBS

PRODUCT NO.  
**TF 4129**