

2" DIA. DRAIN HOLE

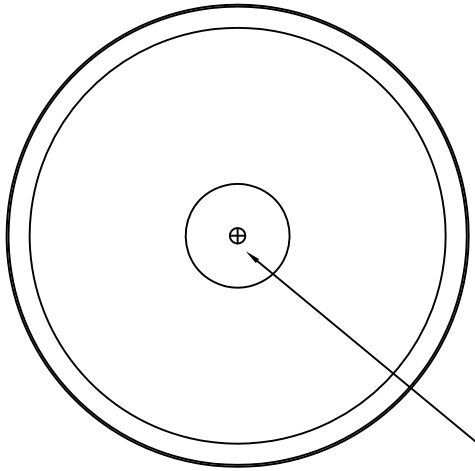

1 TOP VIEW

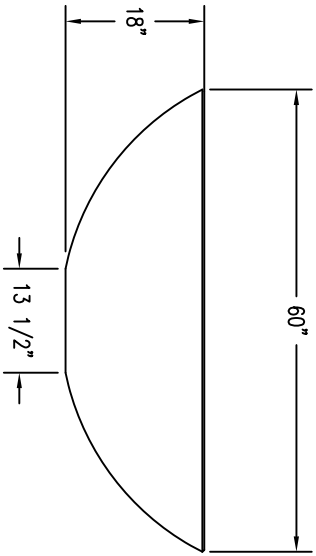

2 ELEVATION VIEW

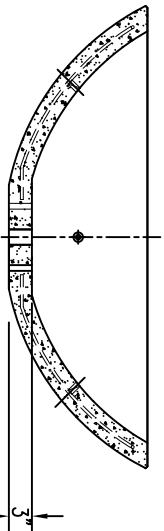

4 CROSS SECTION

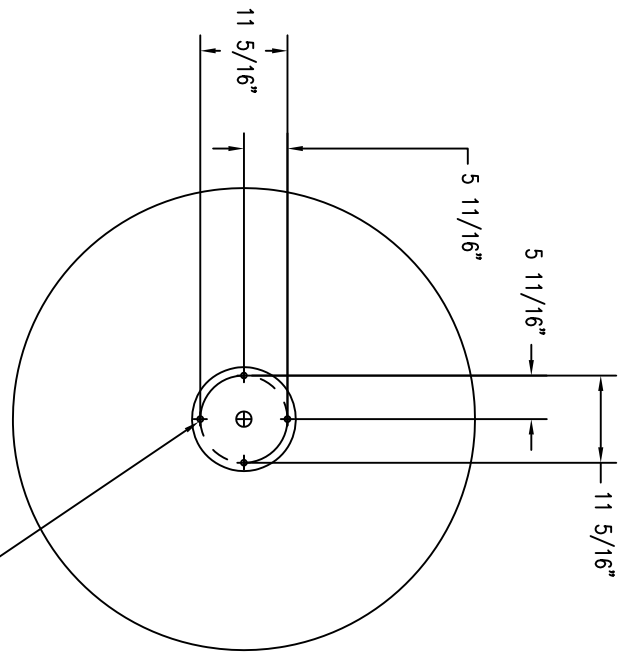

3 BOTTOM VIEW

(4) 3/4"-13 UNC INSERTS



P.O. BOX 1520 WAUSAU, WI 54402-1520  
 E-MAIL: [WATERMAN@TILE.COM](mailto:WATERMAN@TILE.COM)  
 WEB SITE: [WWW.WATERMAN@TILE.COM](http://WWW.WATERMAN@TILE.COM)

REVISIONS

1	NAME	DATE	NOTES
2			
3			
4			
5			
6			
7			
8			

THESE DRAWING SPECIFICATIONS AND ACCOMPANYING THEM ARE THE CONFIDENTIAL AND PROPRIETARY PROPERTY OF WAUSAU TILE, INC. THE DRAWINGS HEREIN SHALL BELONG TO THE OWNER AND SHALL REMAIN THE PROPERTY OF WAUSAU TILE, INC. WITHOUT ANY ADDITIONAL USE SHALL REQUIRE THE PRIOR WRITTEN APPROVAL OF WAUSAU TILE, INC. THE PROPRIETARY INFORMATION CONTAINED WITHIN THE DRAWINGS AND THIS DOCUMENT IS THE SOLE PROPERTY OF WAUSAU TILE, INC.

JOB NAME

ADDRESS  
 CITY, STATE ZIP

UNLESS OTHERWISE SPECIFIED  
 DIMENSIONS ARE IN INCHES  
 FINISHES 3/16"

DRAWN BY: SK  
 DATE: 7/13/15  
 CD NUMBER: 7  
 WEIGHT: 900 LBS

PRODUCT NO.

TF 4128