

1 TOP VIEW

2" DIA. DRAIN HOLE

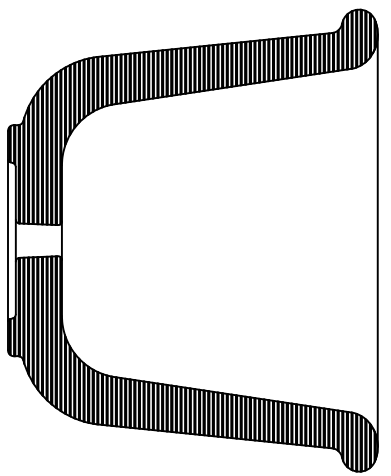

4 CROSS SECTION

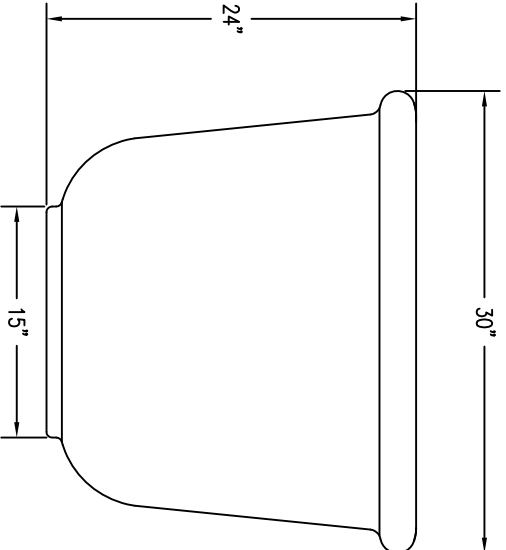

2 ELEVATION VIEW

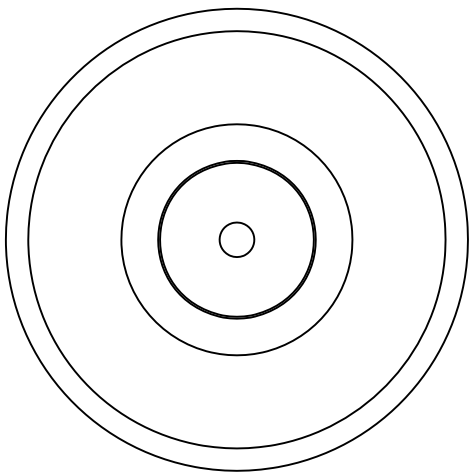

3 BOTTOM VIEW

**MAUSAU TILE**  
 P.O. BOX 1320 MAUSAU, WI 54402-1320  
 E-MAIL: [info@mausautile.com](mailto:info@mausautile.com)  
 WEB SITE: [www.mausautile.com](http://www.mausautile.com)

REVISIONS		
NAME	DATE	NOTES
1		
2		
3		
4		
5		
6		
7		
8		

THESE DRAWING, SPECIFICATIONS AND OTHER INFORMATION ARE THE PROPERTY OF MAUSAU TILE, INC. THE DRAWINGS HEREIN SHALL BELOING TO THE MAUSAU TILE, INC. AND SHALL REMAIN THE PROPERTY OF MAUSAU TILE, INC. THE PROPRIETARY INFORMATION CONTAINED HEREIN IS UNCLASSIFIED AND IS THE SOLE PROPERTY OF MAUSAU TILE, INC.

JOB NAME  
 ADDRESS  
 CITY, STATE ZIP

UNLESS OTHERWISE SPECIFIED  
 DIMENSIONS ARE IN INCHES  
 FINISHES 3/16"  
 DRAWN BY: SK  
 DATE: 8/11/15  
 CD NUMBER: 7  
 WEIGHT: 30 LBS  
 PRODUCT NO.  
**TF 4054**