

REVISIONS		
NAME	DATE	NOTES
1		
2		
3		
4		
5		
6		
7		
8		

THESE DRAWING, SPECIFICATIONS AND OTHER INFORMATION ARE THE PROPERTY OF MAUSAU TILE, INC. THE DRAWINGS AND SPECIFICATIONS SHALL REMAIN THE PROPERTY OF MAUSAU TILE, INC. WITHOUT ANY ADDITIONAL USE SHALL REQUIRE THE PRIOR WRITTEN APPROVAL OF MAUSAU TILE, INC. THE PROPRIETARY INFORMATION CONTAINED HEREIN IS THE BUSINESS AND SOLE PROPERTY OF MAUSAU TILE, INC.

JOB NAME _____
 ADDRESS _____
 CITY, STATE ZIP _____

UNLESS OTHERWISE SPECIFIED
 DIMENSIONS ARE IN INCHES
 FINISHES 3/16"

DRAWN BY: SK
 DATE: 7/2/15
 CD NUMBER: ?
 WEIGHT: 110 LBS

PRODUCT NO.
TF 4045

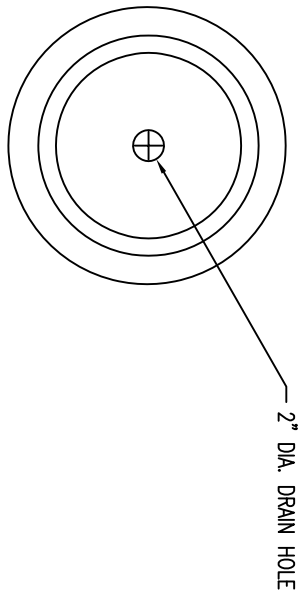

1 TOP VIEW

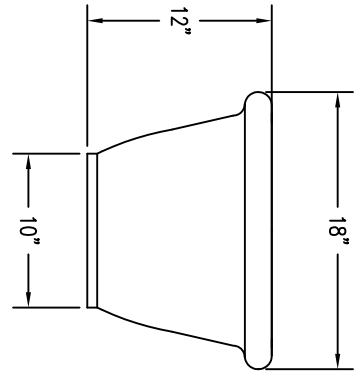

2 ELEVATION VIEW

4 CROSS SECTION

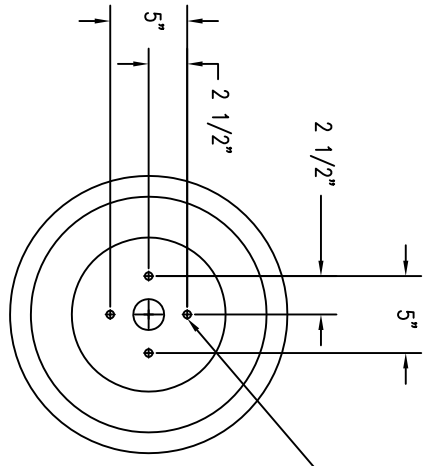
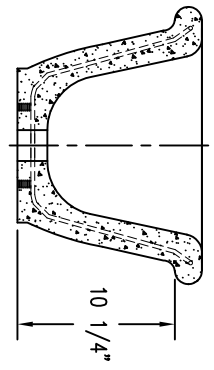

3 BOTTOM VIEW

(4) 1/2" UNC S/S INSERTS