

**1** TOP VIEW  
 Scale: 1/16" = 1"

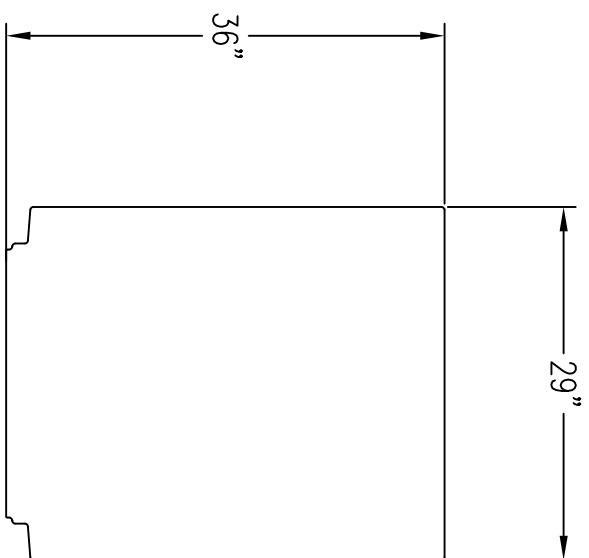

**2** ELEVATION VIEW  
 Scale: 1/16" = 1"

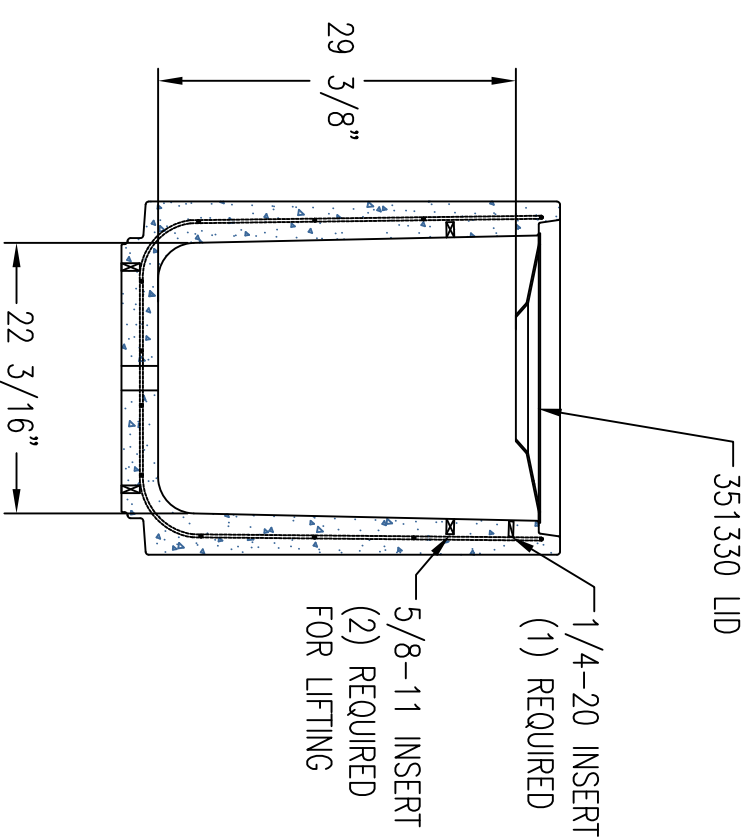
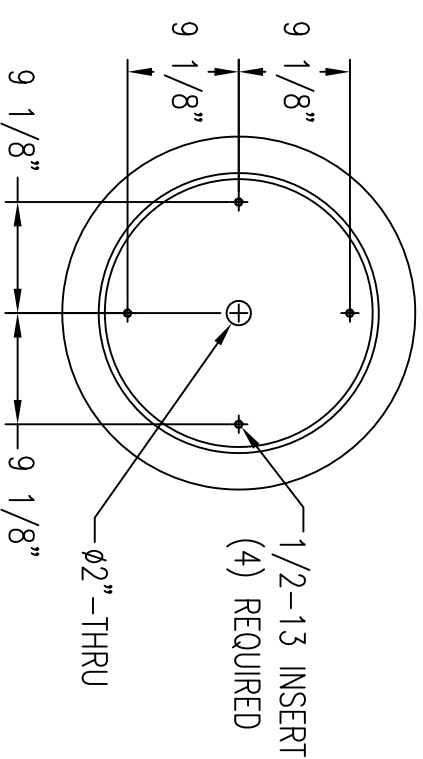

**4** BOTTOM VIEW  
 Scale: 1/16" = 1"

REVISIONS		
NAME	DATE	NOTES
1	---	---
2	---	---
3	---	---
4	---	---
5	---	---
6	---	---
7	---	---
8	---	---

CONFIDENTIAL INFORMATION  
 THESE DRAWING, SPECIFICATIONS AND OTHER INFORMATION AND DOCUMENTS ACCOMPANYING THEM ARE THE CONFIDENTIAL AND PROPRIETARY PROPERTY OF WAUSAU TILE, INC. THE DRAWINGS THEMSELVES SHALL BELONG TO THE OWNER FOR USE ONLY ON THE PROJECT. ANY ADDITIONAL USE SHALL REQUIRE THE PRIOR WRITTEN APPROVAL OF WAUSAU TILE, INC. THE PROPRIETARY INFORMATION CONTAINED WITHIN THE DRAWINGS AND THE DOCUMENTS IS AND SHALL REMAIN THE SOLE PROPERTY OF WAUSAU TILE, INC

JOB NAME \_\_\_\_\_

LOCATION \_\_\_\_\_

UNLESS OTHERWISE SPECIFIED DIMENSIONS ARE IN INCHES FRACTIONS ± 1/8"

DRAWN BY: TAS

DATE: 11/4/16

CO NUMBER: ?

WEIGHT: 910 LBS

SIGN BELOW IF DRAWINGS ARE APPROVED W/ MARKED CHANGES

APPROVED: \_\_\_\_\_

DATE: \_\_\_\_\_

(SIGNATURE ABOVE ILLUSTRATES ACCEPTANCE OF DIMENSIONS SHOWN.)