

1 TOP VIEW

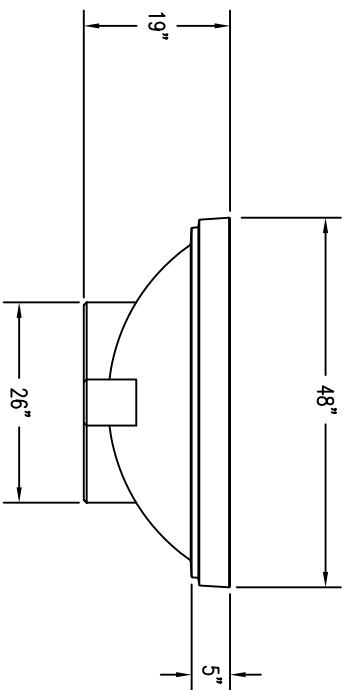

2 ELEVATION VIEW

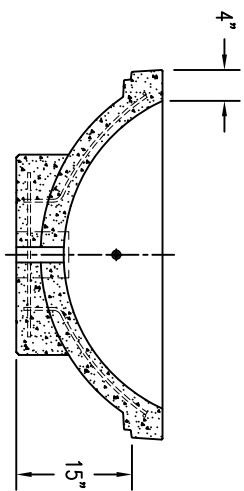

4 CROSS SECTION

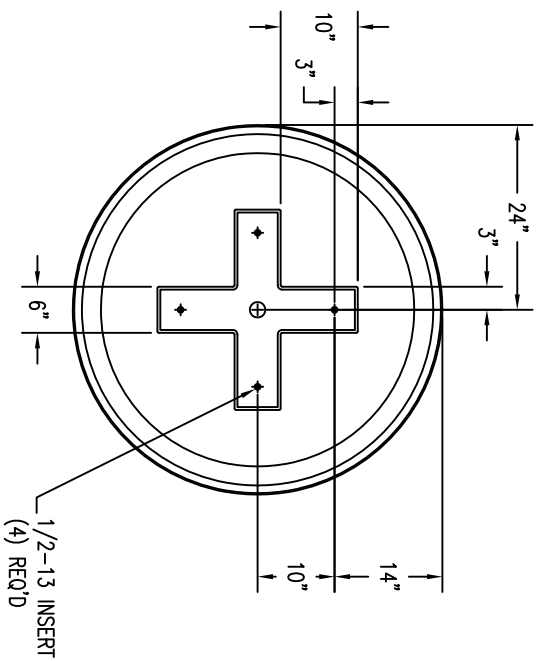

3 BOTTOM VIEW

MAUSAU TILE
 P.O. BOX 1520 WAUSAU, WI 54402-1520
 E-MAIL: WATERMAN@MAUSAUTILE.COM
 WEB SITE: WWW.MAUSAUTILE.COM

REVISIONS		
NAME	DATE	NOTES

THESE DRAWING SPECIFICATIONS AND OTHER INFORMATION ARE THE PROPERTY OF MAUSAU TILE, INC. THE DRAWINGS HEREIN SHALL BELONG TO THE OWNER AND SHALL BE KEPT CONFIDENTIAL AND PROPRIETARY PROPERTY OF MAUSAU TILE, INC. ANY ADDITIONAL USE SHALL REQUIRE THE PRIOR WRITTEN APPROVAL OF MAUSAU TILE, INC. THE PROPRIETARY INFORMATION CONTAINED HEREIN IS UNCLASSIFIED AND IS THE SOLE PROPERTY OF MAUSAU TILE, INC.

JOB NAME
 ADDRESS
 CITY, STATE ZIP

UNLESS OTHERWISE SPECIFIED
 DIMENSIONS ARE IN INCHES
 FINISHES 1/16"

DRAWN BY: SK
 DATE: 7/1/15
 CO NUMBER: ?
 WEIGHT: 600 LBS

PRODUCT NO.
SL 403