

PLANTER DRIP

SHAPE

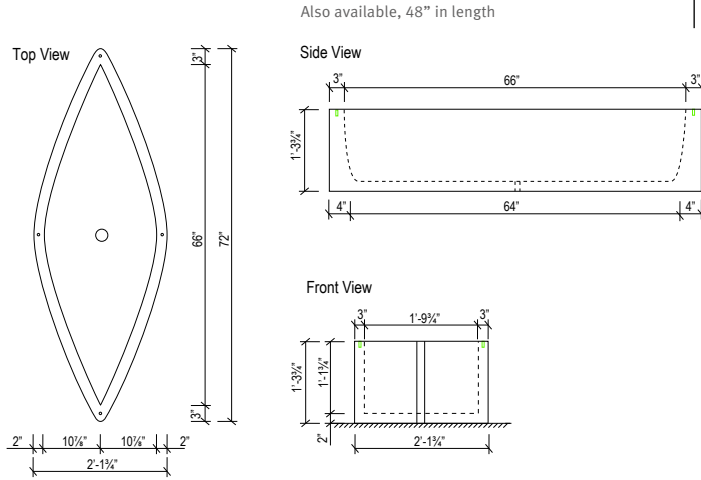

HANDLING*

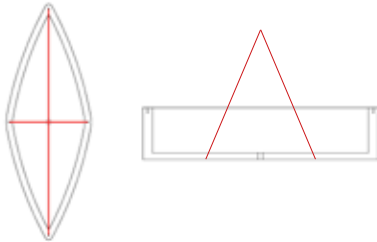

Elements	Length inch	Width inch	Height inch	Weight lbs/p
ZB.DP.01	48	25 1/4	15 3/4	440
ZB.DP.02	72	25 1/4	15 3/4	585

! Special custom manufacturing. Order and delivery time on request

PRODUCT DESCRIPTION

Characteristics

- Prefabricated concrete element
- Finish:
 - > Acid wash : a light acid etch finish with an even and flat texture across the entire surface
 - > Weatherstone : a sandblast finish exposing rock and giving a subtle texture and weathered look
- Free standing
- Factory sealed

Delivery information

- Delivery only on pallets

PROJECT STUDY INFORMATION

- Specific dimensions in custom manufacturing (only on order): on demand

SHIPPING FEES

- On demand

COLORS

Acid wash	Weatherstone
A20 - White	W20 - White
A21 - Buff	W21 - Buff
A22 - Sand	W22 - Sand
A23 - Gray	W23 - Gray
A24 - Brick red	W24 - Brick red
A25 - Brown	W25 - Brown
A26 - Charcoal	W26 - Charcoal
A30 - Star	W30 - Star
A31 - Fog	W31 - Fog
A38 - Night	W33 - Misty gray
	W38 - Night

DESIGNER



Urbastyle Design Team