

1 TOP VIEW
Scale: 1/8" = 1"

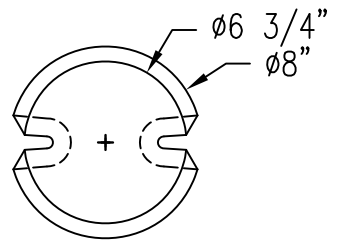

3 BOTTOM VIEW
Scale: 1/8" = 1"

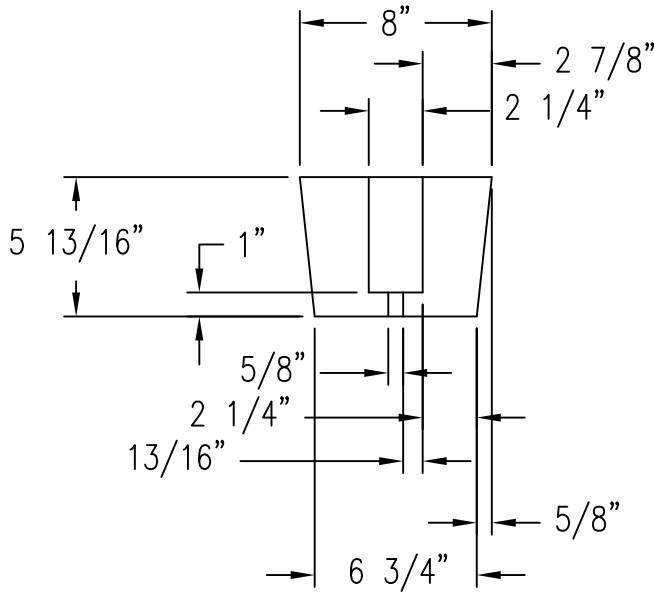

2 ELEVATION VIEW
Scale: 1/8" = 1"

WAUSAU TILE

P.O. BOX 1520 WAUSAU, WISCONSIN 54402-1520 800/388-8728
E-MAIL: WTILE@WAUSAUTILE.COM
WEB SITE: WWW.WAUSAUTILE.COM

| | | | | DRAWN BY JSP | JOB CORE FOR 2403 PLASTIC BENCH | MATERIAL CONCRETE |
|----------|------------------------|-----|--------|----------------|---|-----------------------|
| 4 | | | | JOB NO. | LOCATION | WEIGHT APPROX. 20 LBS |
| 3 | | | | SCALE AS NOTED | UNLESS OTHERWISE SPECIFIED DIMENSIONS ARE IN INCHES TOLERANCES: ±1/8" | ITEM NO. 7128 |
| 2 | | | | FINISH OPTIONS | | DATE 6/17/11 |
| 1 | CHANGED TAPER ON HOLES | JPZ | 7/7/11 | | | |
| REVISION | DESCRIPTION | BY | DATE | | | |