

1 SECTION OF SS-30 TREAD
Scale: 6" = 1'-0"

MAXIMUM TREAD LENGTH: 96"
4" MINIMUM THICKNESS

LANDING PANELS AVAILABLE IN 4" THICKNESS.
MAXIMUM PANEL SIZE IS 20 SF

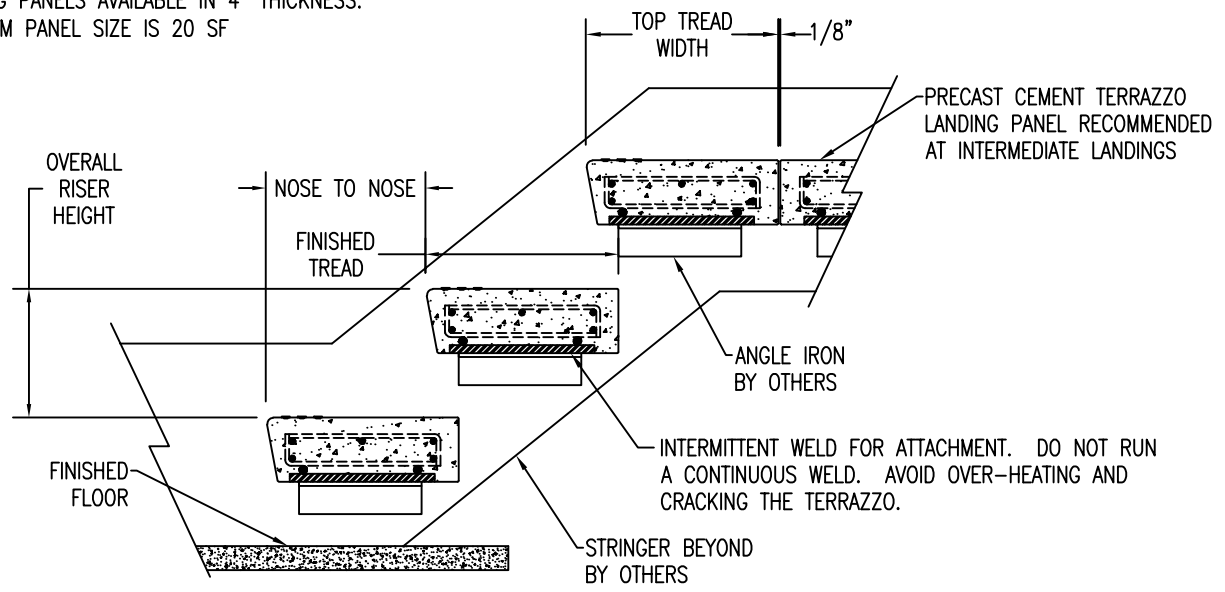

2 PARTIAL STAIR SECTION SS-30 TREAD
Scale: 1 1/2" = 1'



P: 800.388.8728
E: WTILE@WAUSAUTILE.COM
WWW.WAUSAUTILE.COM

CONFIDENTIAL INFORMATION
THESE DRAWING, SPECIFICATIONS AND OTHER INFORMATION AND DOCUMENTS ACCOMPANYING THEM ARE THE CONFIDENTIAL AND PROPRIETARY PROPERTY OF WAUSAU TILE, INC. THE DRAWINGS THEMSELVES SHALL BELONG TO THE OWNER FOR USE ONLY ON THE PROJECT. ANY ADDITIONAL USE SHALL REQUIRE THE PRIOR WRITTEN APPROVAL OF WAUSAU TILE, INC. THE PROPRIETARY INFORMATION CONTAINED WITHIN THE DRAWINGS AND THE DOCUMENTS IS AND SHALL REMAIN THE SOLE PROPERTY OF WAUSAU TILE, INC

PRECAST TERRAZZO
SS-30 CEMENT TREAD

REVISIONS				DRAWN BY: MR
	NAME	DATE	NOTES	
1	---	---	---	DATE: 10/21/14
2	---	---	---	SCALE: AS NOTED
3	---	---	---	SHEET NO. 22
4	---	---	---	